

HONDA
GENUINE PARTS



2

APPLICATION OF PARTS LIST

This is a list of parts used on the HONDA 50
Model Z50A

1. How to read the Part Number

The composition of Part Number is as follows.

(Example)

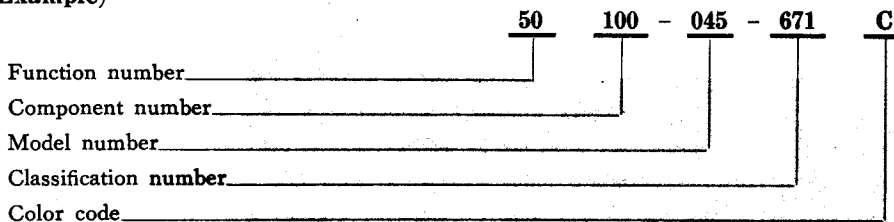

2. How to Order Parts

When placing orders to us, inform us the correct part number by referring to this Part List.

When changing parts, check the frame number, then the parts used can be found.

3. Regarding the News Number

News number is the number of the Parts News issued by Honda Service Division. Refer to the Parts News when you need to know the contents of modified parts and related parts in detail.

4. This Parts List can be revised with Revision Sheet

Keep this Parts List up-to-date by replacing or inserting Revision Sheets issued periodically.

Please put the Revision Sheet in the place of each page according to instruction shown at the bottom of the sheet.

If you make sure of this, the Parts List will be kept always up-to-date.

5. Parts with ● marks.

Those parts with ● marks in the text as well as in the index are either newly introduced or changed items in this issue.

6. This Parts List was compiled as of 25th January, 1969 and covers the changes announced by the Parts News up to No. 9003.

ISO THREADED PARTS

- Not interchangeable with the previous threaded parts -

Threaded parts used in this model conform to the Thread Standard of ISO (International Standardization Organization), and are different from those used in the earlier models.

For servicing this model, therefore, tool set for the earlier models is not sufficient. Socket or box wrenches for 5.5 mm, 7 mm, 12 mm, 22 mm, 24 mm and 27 mm in width across the flats will become necessary.

ISO threads with 3 mm, 4 mm, 5 mm and 12 mm thread diameters are different in pitches from the earlier threads, therefore, confused use of threaded parts will result in damages to threads.

Change in pitch

Thread Diameter	Earlier Pitch	ISO Pitch
3 mm	0.6	0.5
4 mm	0.75	0.7
5 mm	0.9	0.8
12 mm	1.5	1.25

Width across flat



Pitch

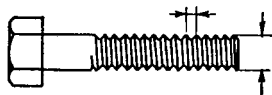

Thread diameter

How to identify ISO threaded parts

For easy identification, the following markings are made on the new ISO threaded parts.

Hex. bolts  ← Presence of figure on the bolt head

Cross screws  ← Semi-spherical embossement on the head

Nuts  ← Semi-spherical dimple

They can also be identified by the part numbers.

92000 - 08012 - OA

Those parts with this marking at the end of the part numbers are of ISO threads.

For further details, please refer to Service Bulletin No. 004 dated April 20, 1967.

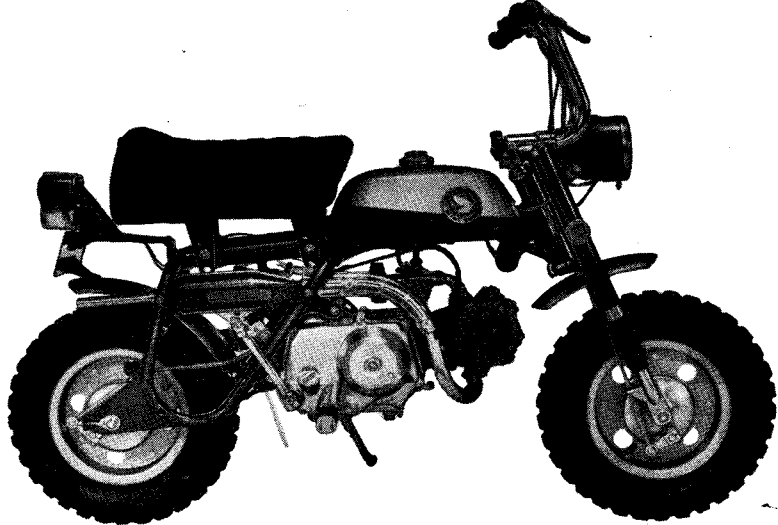

NEW MODEL

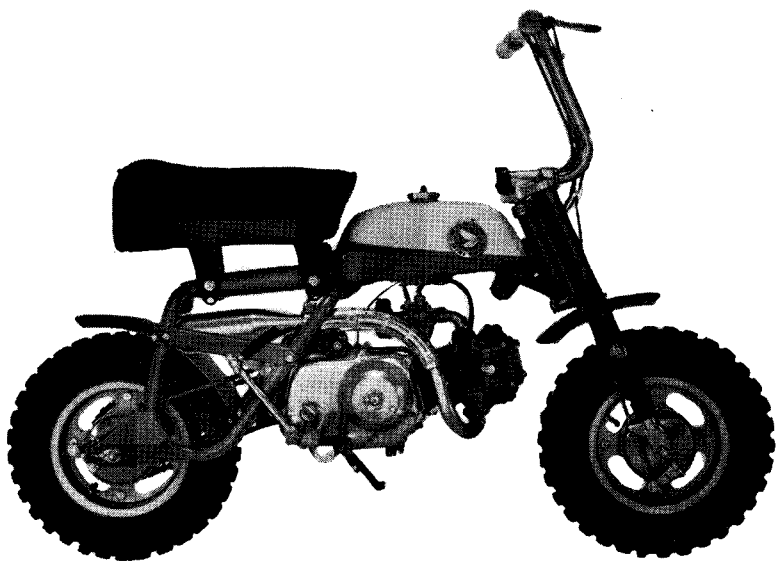

FORMER MODEL

CONTENTS

ENGINE GROUP

Ref. No.	Nomenclature	Page
E- 1.....	Cylinder • Cylinder Head	2
E- 2.....	Crankshaft	4
E- 3.....	Camshaft • Valve	6
E- 4.....	Cam Chain Tensioner	8
E- 5.....	Crankcase	10
E- 6.....	Clutch	12
E- 7.....	Oil Pump • Right Crankcase Cover	16
E- 8.....	Transmission	20
E- 9.....	Gear Change	22
E-10.....	Gear Shift Drum	24
E-11.....	Left Crankcase Cover • Dynamo.....	26
E-12.....	Carburetor	28

FRAME GROUP

F- 1.....	Steering Handle	32
F- 2.....	Front Cushion • Front Fork.....	36
F- 3.....	Fuel Tank	38
F- 4.....	Seat • Step Bar	40
F- 5.....	Frame Body • Air Cleaner	42
F- 6.....	Muffler	46
F- 7.....	Front Wheel	48
F- 8.....	Rear Wheel	50
F- 9.....	Head Light • Head Light Case	54
F-10.....	Tail Light • Rear Fender.....	56
F-11.....	Wire Harness • Battery.....	58
Y- 1.....	Support Stand.....	60
Y- 2.....	Optional Driven Sprocket	62
Y- 3.....	Packing Set	64

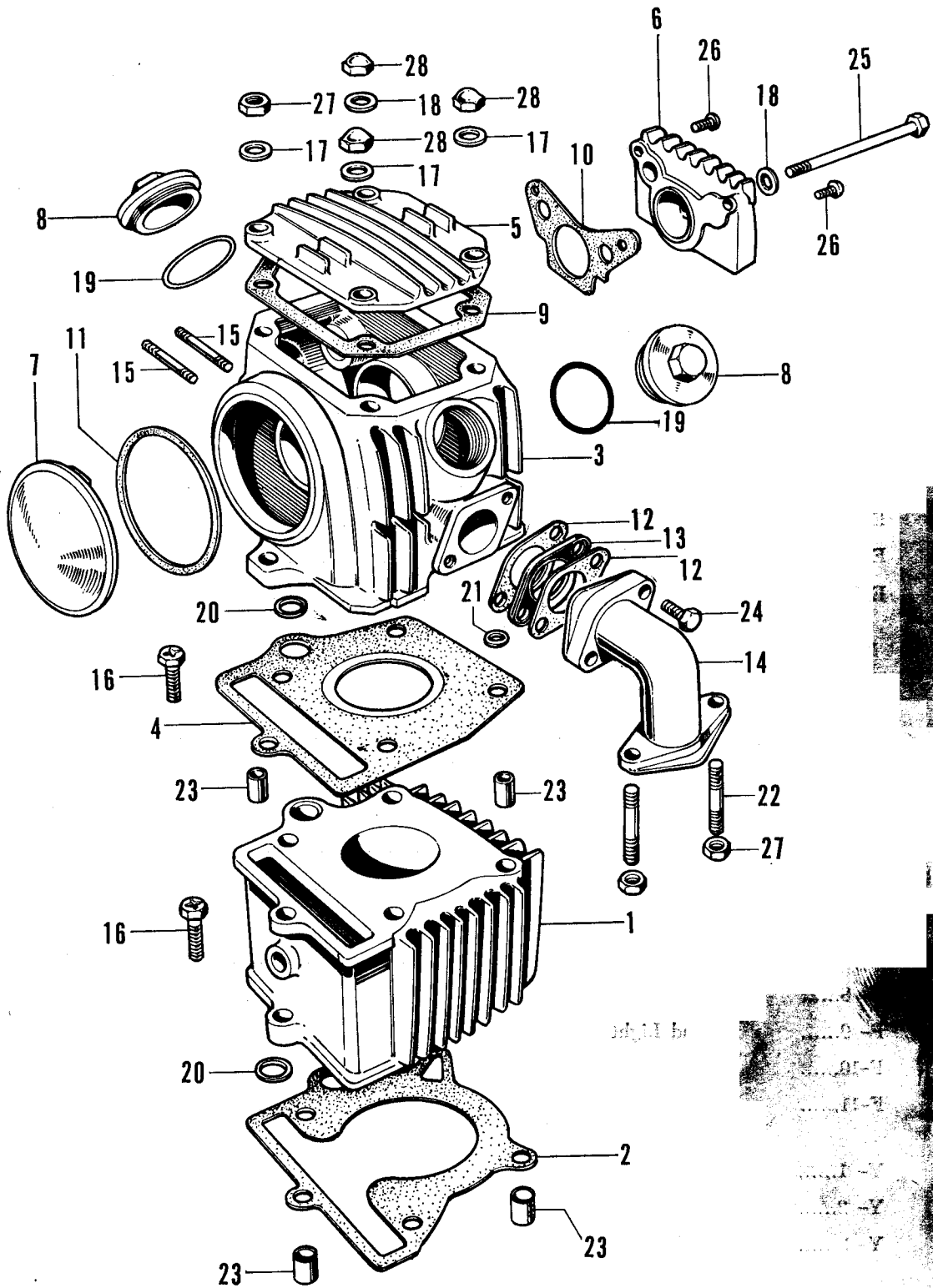

E-1 Cylinder · Cylinder Head

HONDA

Ref. No.	Part No.	Description	Reqd. No. Z50A	No. Used on		News No.
				From	To	
1	12101-041-030	CYLINDER	1	Z50A-100001		
2	12191-035-010	GASKET, cylinder	1	Z50A-100001		
3	12200-041-020	HEAD, cylinder	1	Z50A-100001		
4	12251-036-010	GASKET, cylinder head	1	Z50A-100001		
5	12301-035-000	COVER, cylinder head	1	Z50A-100001		
6	12331-035-000	COVER, right side, cylinder head.....	1	Z50A-100001		
7	12341-035-000	COVER, left side, cylinder head	1	Z50A-100001		
8	12361-035-000	CAP, tappet adjusting hole	2	Z50A-100001		
9	12391-035-000	GASKET, cylinder head cover	1	Z50A-100001		
10	12394-035-000	GASKET, cylinder head right side cover	1	Z50A-150001		
11	12395-035-000	GASKET, cylinder head left side cover.	1	Z50A-100001		
12	16201-045-000	GASKET, insulator	2	Z50A-100001		
13	16211-045-010	INSULATOR, inlet pipe	1	Z50A-100001		
14	17111-045-040	PIPE, inlet	1	Z50A-100001		
15	90033-041-000	STUD BOLT, 6×32	2	Z50A-100001		
16	90082-035-000	BOLT, HS., 6 mm	2	Z50A-100001		
17	90442-035-000	WASHER, sealing, 6 mm	3	Z50A-100001		
18	90443-035-000	WASHER A, sealing, 6 mm	2	Z50A-100001		
19	91302-001-020	O RING, 31.5 mm	2	Z50A-100001		
20	91303-035-000	PACKING, rubber, 16 mm	2	Z50A-100001		
21	91306-035-000	GASKET, rubber, 7.5 mm	1	Z50A-100001		
22	92712-0602510	STUD, 6×25	2	Z50A-100001		8004
23	94301-08140	PIN, knock, 8×14A	4			
24	92000-06025	BOLT, hex., 6×25	2			
25	92000-06112	BOLT, hex., 6×112	1			
26	93500-06010	SCREW, cross, 6×10	2			
27	94001-06000	NUT, hex., 6 mm	3			
28	94021-06000	NUT, blind, 6 mm	3			

ENGINE GROUP

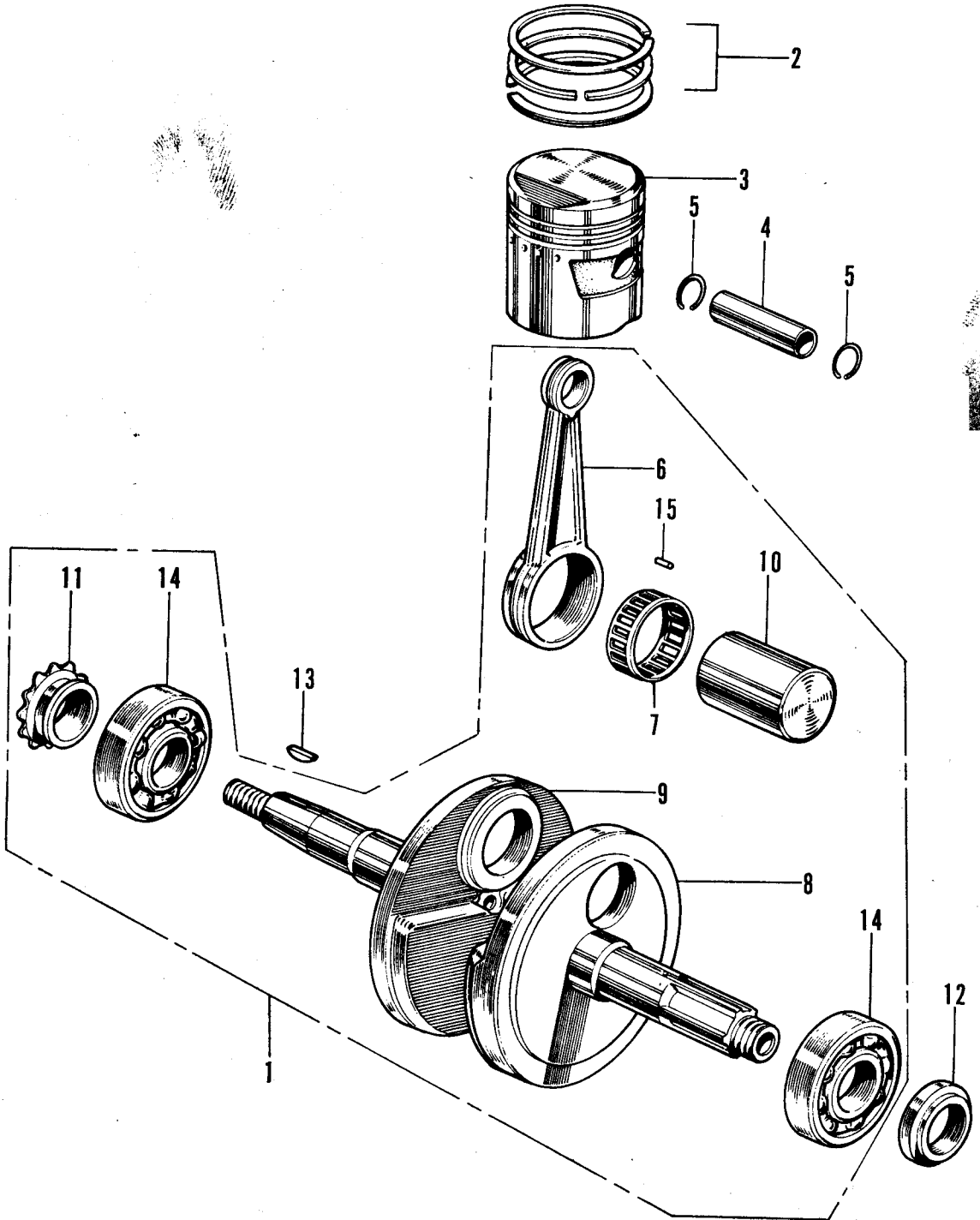

Ref. No.	Part No.	Description	Reqd. No. Z50A	No. Used on		News No.
				From	To	
1	13000-041-030	CRANKSHAFT ASSY.	1	Z50A-100001		
2	13010-036-000	RING-SET, piston (S.T.D.).....	1	Z50A-100001		
	13020-036-000	RING-SET, piston (0.25).....	1	Z50A-100001		
	13030-036-000	RING-SET, piston (0.50).....	1	Z50A-100001		
	13040-036-000	RING-SET, piston (0.75).....	1	Z50A-100001		
	13050-036-000	RING-SET, piston (1.00).....	1	Z50A-100001		
3	13101-036-010	PISTON (S.T.D.)	1	Z50A-100001		
	13102-036-010	PISTON (0.25).....	1	Z50A-100001		
	13103-036-010	PISTON (0.50).....	1	Z50A-100001		
	13104-036-010	PISTON (0.75).....	1	Z50A-100001		
	13105-036-010	PISTON (1.00).....	1	Z50A-100001		
4	13111-036-000	PIN, piston	1	Z50A-100001		
5	13115-001-000	CLIP, piston pin.....	2	Z50A-100001		
6	13201-036-000	ROD, connecting.....	1	Z50A-100001		
7	13211-035-000	RETAINER, roller.....	1	Z50A-100001		
8	13310-035-050	CRANKSHAFT, right	1	Z50A-100001		
9	13321-041-020	CRANKSHAFT, left	1	Z50A-100001		
10	13381-035-010	PIN, crank.....	1	Z50A-100001		
11	14311-035-000	SPROCKET, timing	1	Z50A-100001		
12	22911-035-010	COLLAR, 17 mm	1	Z50A-100001		
13	90741-035-000	KEY, woodruff.....	1	Z50A-100001		
14	91001-035-000	BEARING, ball, 6304	2	Z50A-100001		
15	91101-001-030	ROLLER, 2.5×10	22	Z50A-100001		

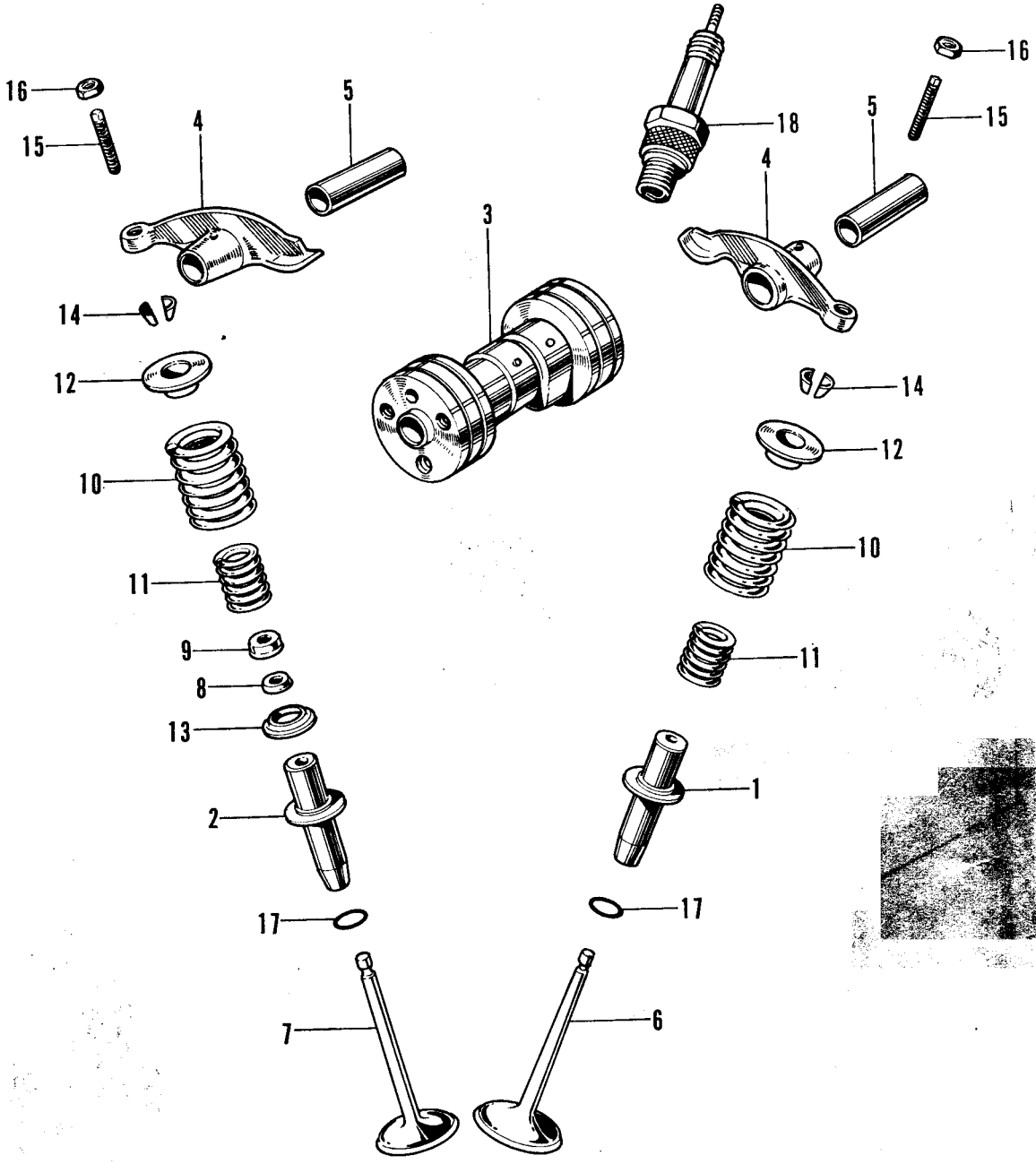

E-3 Camshaft · Valve

HONDA

Ref. No.	Part No.	Description	Reqd. No. Z50A	No. Used on		News No.
				From	To	
1	12021-035-811	GUIDE, inlet valve.....	1	Z50A-100001		
2	12023-051-310	GUIDE, exhaust valve	1	Z50A-100001		
3	14101-041-010	CAMSHAFT	1	Z50A-100001	Z50A-108925	
●	14101-041-020	CAMSHAFT	1	Z50A-108296		9001
4	14431-035-000	ARM, valve locker.....	2	Z50A-100001		
5	14451-035-000	SHAFT, valve locker arm	2	Z50A-100001		
6	14711-036-000	VALVE, inlet	1	Z50A-100001		
7	14721-036-000	VALVE, exhaust.....	1	Z50A-100001		
8	14730-028-000	SEAL, valve stem	1	Z50A-100001		
9	14731-028-000	CAP, valve stem seal.....	1	Z50A-100001		
10	14751-035-600	SPRING, valve (outer)	2	Z50A-100001		
11	14761-035-000	SPRING, valve (inner)	2	Z50A-100001		
12	14771-035-600	RETAINER, valve spring	2	Z50A-100001		
13	14776-028-000	SEAT, inner valve spring	1	Z50A-100001		
14	14781-001-010	COTTER, valve	4	Z50A-100001		
15	90012-200-000	SCREW, tappet adjusting.....	2	Z50A-100001		
16	90206-001-000	NUT, tappet adjusting	2	Z50A-100001		
17	91306-028-000	O RING, 9.5×1.6	2	Z50A-100001		
18	98056-56711	PLUG, sparking (C-6H, NGK)	1			
	98056-56721	PLUG, sparking (C-20FS)	1			
		(NIPPON DENSO)				

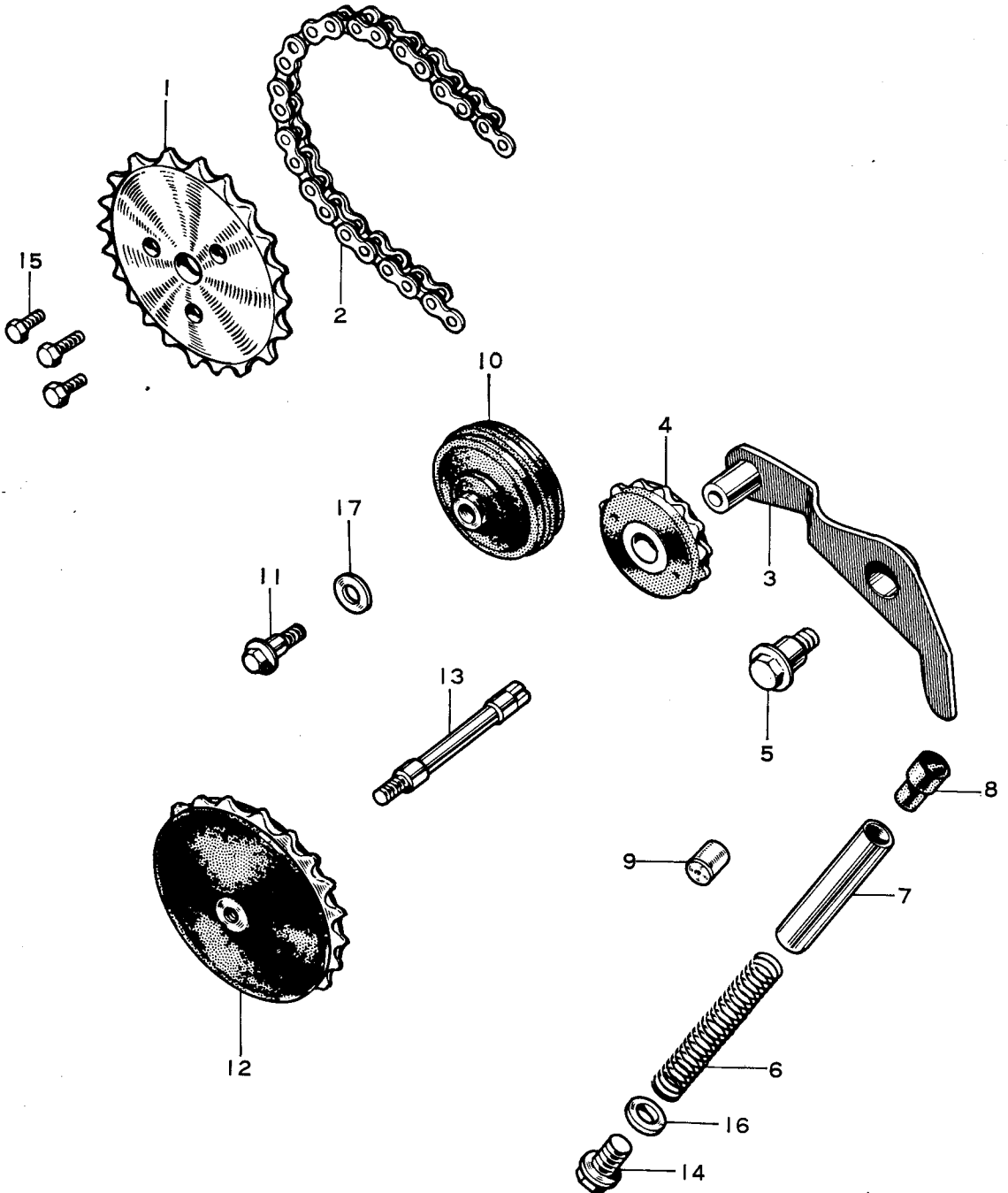

Ref. No.	Part No.	Description	Reqd. No. Z50A	No. Used on		News No.
				From	To	
1	14321-035-010	SPROCKET, cam	1	Z50A-100001		
2	14401-035-000	CHAIN, cam (82L).....	1	Z50A-100001		
3	14500-035-010	ARM, tensioner	1	Z50A-100001		
4	14502-035-310	ROLLER, cam chain tensioner	1	Z50A-100001		
5	14531-035-000	PIVOT, cam chain tensioner	1	Z50A-100001		
6	14541-035-010	SPRING, tensioner.....	1	Z50A-100001		
7	14551-035-020	ROD, tensioner push.....	1	Z50A-100001		
8	14566-035-000	RUBBER, tensioner push rod head	1	Z50A-100001		
9	14591-028-000	VALVE, check.....	1	Z50A-100001		
10	14610-035-010	ROLLER, cam chain guide.....	1	Z50A-100001		
11	14615-035-000	PIN, guide roller.....	1	Z50A-100001		
12	14670-035-030	SPROCKET, cam chain guide	1	Z50A-100001		
13	14675-035-060	SPINDLE, cam chain guide sprocket ...	1	Z50A-100001		
14	90081-035-000	BOLT, sealing, 14 mm	1	Z50A-100001		
15	90083-035-000	BOLT, knock, 5 mm	3	Z50A-100001	Z50A-108925	
•	90083-035-010	BOLT, knock, 5 mm	3	Z50A-108926		9001
16	90441-035-000	WASHER, sealing, 14 mm	1	Z50A-100001		
17	90481-035-000	WASHER, 8 mm.....	1	Z50A-100001		

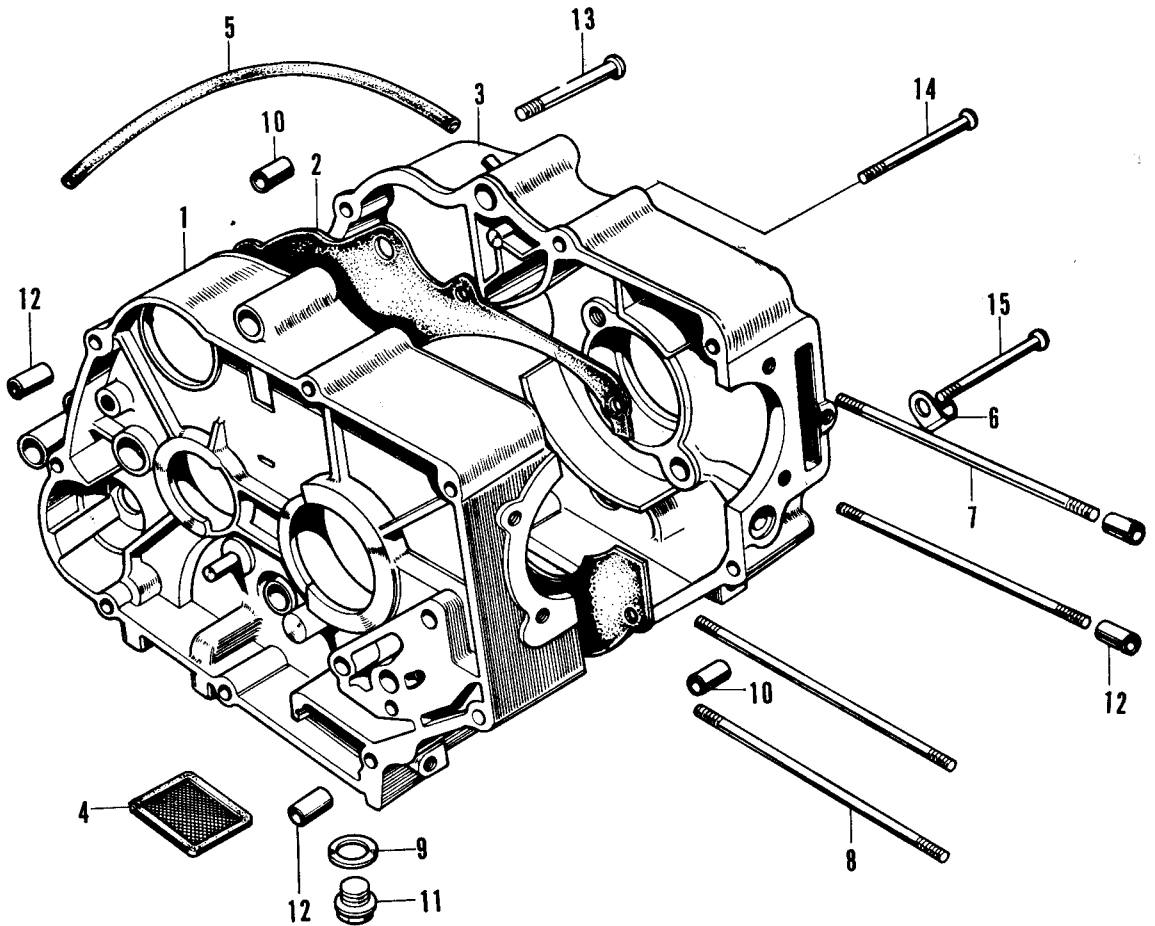

E-5 Crankcase**HONDA**

Ref. No.	Part No.	Description	Reqd. No. Z50A	No. Used on		News No.
				From	To	
1	11100-045-000	CRANKCASE, right	1	Z50A-100001		
2	11191-035-040	GASKET, right crankcase	1	Z50A-100001		
3	11200-045-040	CRANKCASE, left	1	Z50A-100001		
4	15421-035-010	SCREW, oil filter	1	Z50A-100001		
5	15761-045-000	PIPE, breather.....	1	Z50A-100001		
6	16236-045-000	CLAMPER, over flow pipe.....	1	Z50A-100001		
7	90031-035-010	STUD, cylinder	2	Z50A-100001		
8	90032-035-000	STUD B, cylinder	2	Z50A-100001		
9	90407-259-000	PACKING, drain cock	1	Z50A-100001		
● 10	90704-035-000	PIN, knock, 10×14A.....	2	Z50A-100001		
11	92800-12000	BOLT, drain cock	1			
12	94301-08120	PIN, knock, 8×12A	4			
13	93500-0604820	SCREW, cross, 6×48	1			
14	93500-0606020	SCREW, cross, 6×60	3			
15	93500-0606520	SCREW, cross, 6×65	4			

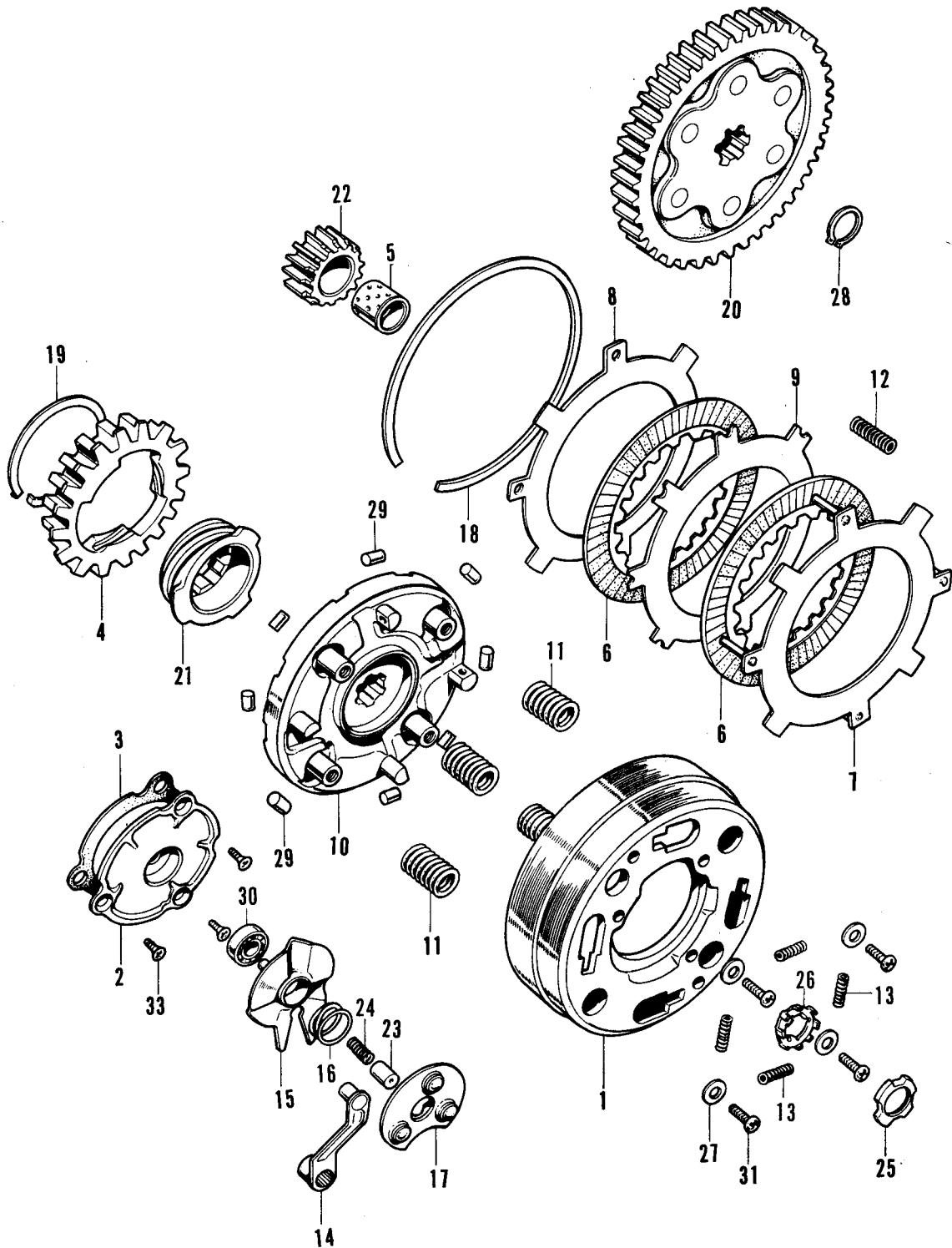

Ref. No.	Part No.	Description	Reqd. No. Z50A	No. Used on		News No.
				From	To	
1	22101-040-010	OUTER, clutch	1	Z50A-100001	Z50A-108295	
●	22101-040-030	OUTER, clutch	1	Z50A-108296		9001
2	22111-040-000	COVER, clutch outer.....	1	Z50A-100001		
3	22119-040-000	GASKET, clutch outer cover.....	1	Z50A-100001		
4	22120-040-010	CENTER, clutch (17T).....	1	Z50A-100001		
5	22131-035-020	GUIDE, clutch center	1	Z50A-100001		
6	22201-040-000	DISK, clutch friction.....	2	Z50A-100001		
7	22310-041-010	PLATE A, clutch	1	Z50A-100001		
8	22321-041-000	PLATE B, clutch	1	Z50A-100001		
9	22331-041-000	PLATE C, clutch	1	Z50A-100001		
10	22351-040-060	PLATE, drive	1	Z50A-100001	Z50A-108295	
●	22351-040-070	PLATE, drive	1	Z50A-108296		9001
11	22401-040-010	SPRING, clutch	4	Z50A-100001		
12	22411-041-000	SPRING, clutch free	4	Z50A-100001		
13	22421-040-000	SPRING, clutch damper	4	Z50A-100001		
14	22811-040-020	LEVER, clutch.....	1	Z50A-100001		
15	22820-046-000	PLATE, clutch cam	1	Z50A-100001		
16	22825-046-000	SPRING, cam plate side	1	Z50A-100001		
17	22860-041-000	RETAINER, ball.....	1	Z50A-100001		
18	22901-001-000	SET-RING, 101.5 mm	1	Z50A-100001		
19	22901-040-000	SET-RING, 45 mm.....	1	Z50A-100001		
20	23110-036-000	GEAR, primary driven (67T).....	1	Z50A-100001		

Ref. No.	Part No.	Description	Reqd. No. Z50A	No. Used on		News No.
				From	To	
21	23112-041-010	GEAR, outer, drive (18T)	1	Z50A-100001		
22	23120-036-010	GEAR, primary drive (18T)	1	Z50A-100001		
● 23	25551-040-007	THROUGH, oil	1	Z50A-100001		8001
24	25555-065-000	SPRING, oil through.....	1	Z50A-100001		
25	90231-041-000	NUT, lock, 14 mm	1	Z50A-100001		
26	90431-001-000	WASHER, lock, 14 mm	1	Z50A-100001		
27	90483-040-000	WASHER, stopper	4	Z50A-100001		
28	90601-001-000	CIR-CLIP, 17 mm	1	Z50A-100001		
29	91102-041-000	ROLLER, 8×10	8	Z50A-100001		
● 30	96100-60000	BEARING, ball, 6000.....	1			8004
31	93500-05008	SCREW, pan, 5×8.....	4			
●	93500-05008-0A	SCREW, pan, 5×8.....	4			9001
32	93600-05010	SCREW, flat, 5×10	3			
●	93600-05010-0A	SCREW, flat, 5×10	3			9001

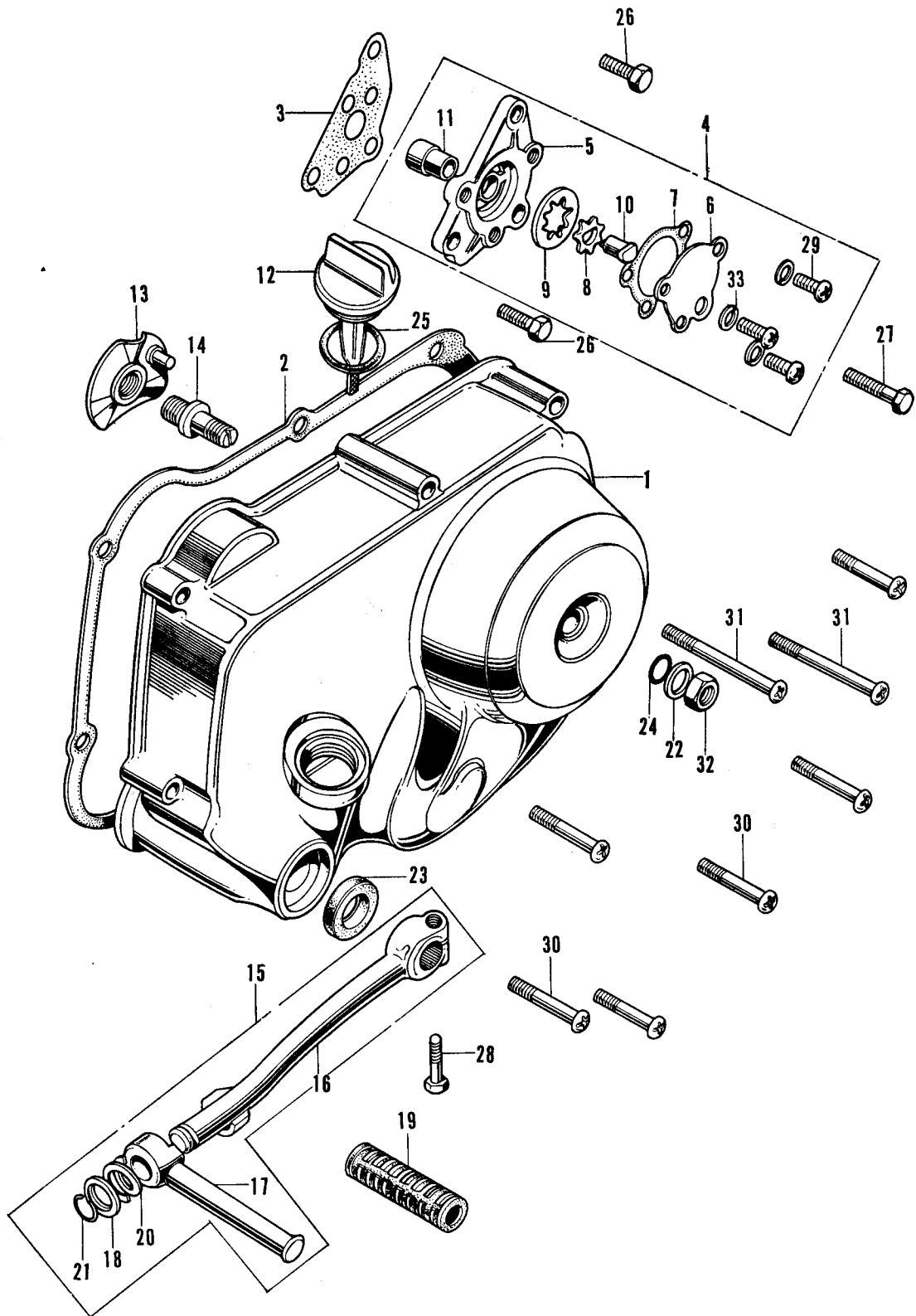

Ref. No.	Part No.	Description	Reqd. No. Z50A	No. Used on		News No.
				From	To	
1	11330-045-010	COVER, right crankcase	1	Z50A-100001		
2	11394-035-000	GASKET, right crankcase cover	1	Z50A-100001		
3	15119-035-020	GASKET, oil pump body	1	Z50A-100001		
4	15300-035-000	PUMP ASSY., oil	1	Z50A-100001		
5	15311-035-000	BODY, oil pump.....	1	Z50A-100001	Z50A-108955	
●	15311-035-013	BODY, oil pump.....	1	Z50A-108956		9001
6	15321-035-000	COVER, oil pump	1	Z50A-100001		
7	15329-035-000	GASKET, oil pump cover	1	Z50A-100001		
8	15331-035-000	ROTOR, inner, oil pump.....	1	Z50A-100001		
9	15332-035-000	ROTOR, outer, oil pump.....	1	Z50A-100001		
10	15382-035-000	SHAFT, oil pump drive	1	Z50A-100001		
11	15383-035-000	PIN, oil pump knock.....	1	Z50A-100001		
12	15650-051-690	GAUGE, oil	1	Z50A-100001		
13	22830-041-000	PLATE, clutch lifter	1	Z50A-100001		
14	22846-040-010	BOLT, clutch adjusting.....	1	Z50A-100001		
15	28300-033-000	ARM ASSY., kick starter	1	Z50A-100001		
16	28301-053-000	ARM, kick starter	1	Z50A-100001		
17	28302-033-000	PEDAL, kick starter	1	Z50A-100001		
18	28303-001-000	WASHER, kick starter knuckle.....	1	Z50A-100001		
19	28311-001-000	RUBBER, kick starter	1	Z50A-100001		
20	28322-001-000	SPRING, kick starter knuckle	1	Z50A-100001		

E-7 Oil Pump · Right Crankcase Cover

HONDA

Ref. No.	Part No.	Description	Reqd. No. Z50A	No. Used on		News No.
				From	To	
21	28324-001-000	CLIP, kick starter knuckle	1	Z50A-100001		
22	90485-040-000	WASHER, 8 mm	1	Z50A-100001		
23	91202-216-000	OIL-SEAL, SB-type, 14-24-5	1	Z50A-100001		
24	91303-001-000	O RING, 8 ϕ	1	Z50A-100001		
25	91307-035-000	O RING, 18 \times 3	1	Z50A-100001		
26	92000-06016	BOLT, hex., 6 \times 16	2			
27	92000-06020	BOLT, hex., 6 \times 20	1			
28	92000-06022	BOLT, hex., 6 \times 22	1			
●	93500-05010-0A	SCREW, pan, 5 \times 10	3			9001
29	93500-05010	SCREW, pan, 5 \times 10	3			
30	93500-0603820	SCREW, pan, 6 \times 38	6			
31	93500-0606520	SCREW, pan, 6 \times 65	2			
32	94001-08000	NUT, hex., 8 mm	1			
33	94111-05000	WASHER, spring, 5 mm	3			

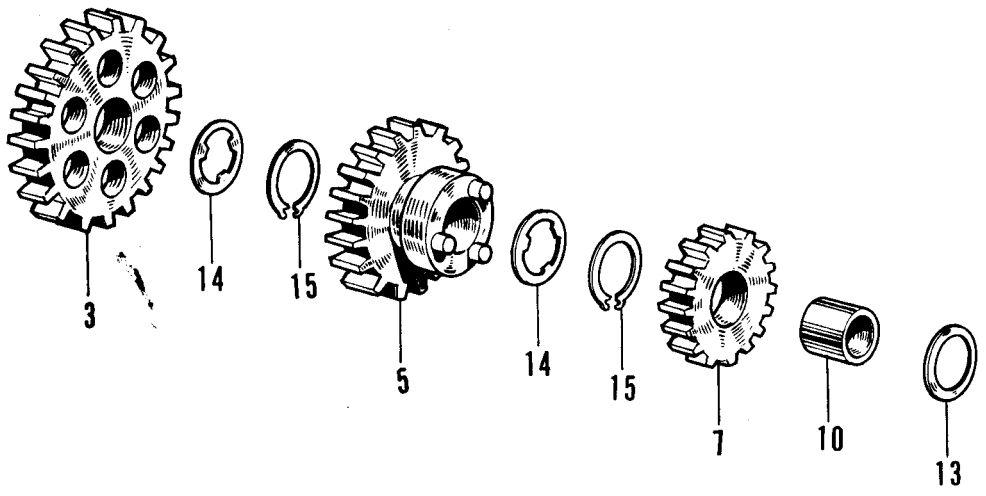
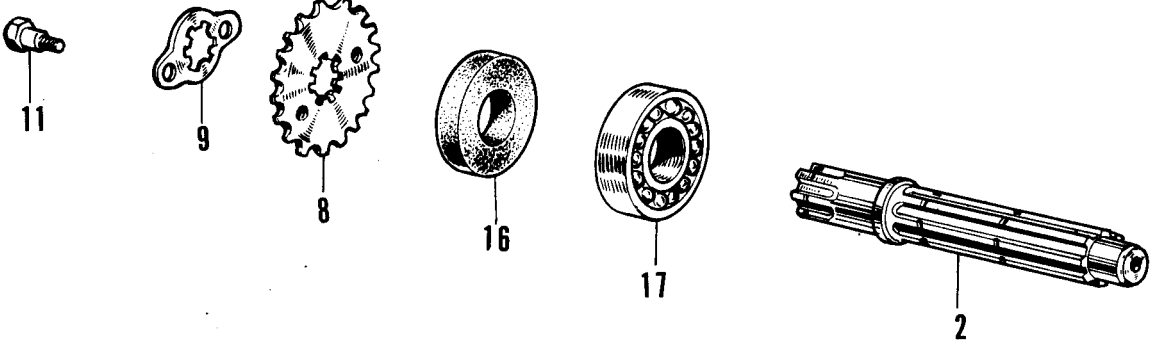
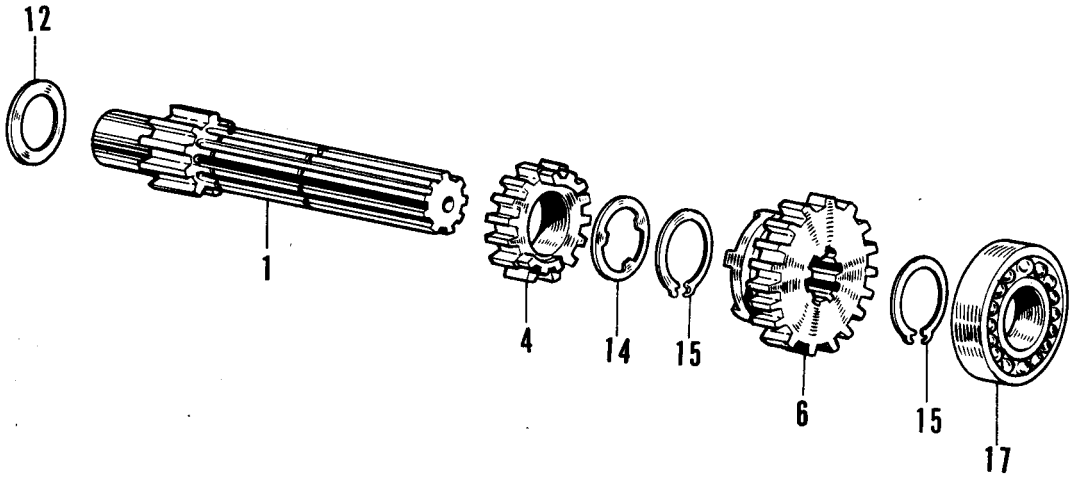

Ref. No.	Part No.	Description	Reqd. No. Z50A	No. Used on		News No.
				From	To	
1	23211-041-020	SHAFT, main, transmission (11T).....	1	Z50A-100001		
2	23221-041-040	SHAFT, counter, transmission	1	Z50A-100001		
3	23421-076-000	GEAR, low, counter shaft (35T).....	1	Z50A-100001		
4	23431-041-040	GEAR, second, main shaft (17T)	1	Z50A-100001		
5	23441-041-060	GEAR, second, counter shaft (31T).....	1	Z50A-100001		
6	23471-041-040	GEAR, top, main shaft (21T).....	1	Z50A-100001		
7	23481-041-020	GEAR, top, counter shaft (25T).....	1	Z50A-100001		
8	23800-045-000	SPROCKET, drive (13T).....	1	Z50A-100001	Z50A-106900	
●	23800-045-670	SPROCKET, drive (12T)	1	Z50A-106901	Z50A-120087	8010
●	23800-045-671	SPROCKET, drive (12T)	1	Z50A-120088		9003
9	23802-041-000	PLATE, drive sprocket fixing.....	1	Z50A-100001	Z50A-106900	
●	23802-065-305	PLATE, drive sprocket fixing	1	Z50A-106901		8010
10	23911-041-010	COLLAR, gear	1	Z50A-100001		
11	90084-041-000	BOLT, drive sprocket fixing	2	Z50A-100001		
12	90451-001-000	WASHER, thrust	1	Z50A-100001		
13	90451-035-000	WASHER, thaustr, 13.5 mm	1	Z50A-100001		
14	90461-001-000	WASHER, spline, 17 mm.....	3	Z50A-100001		
15	90601-001-000	CIR-CLIP, 17 mm	4	Z50A-100001		
16	91203-035-000	OIL-SEAL, 17-29-5	1	Z50A-100001		
17	96100-62030	BEARING, ball, 6203.....	2	Z50A-100001		

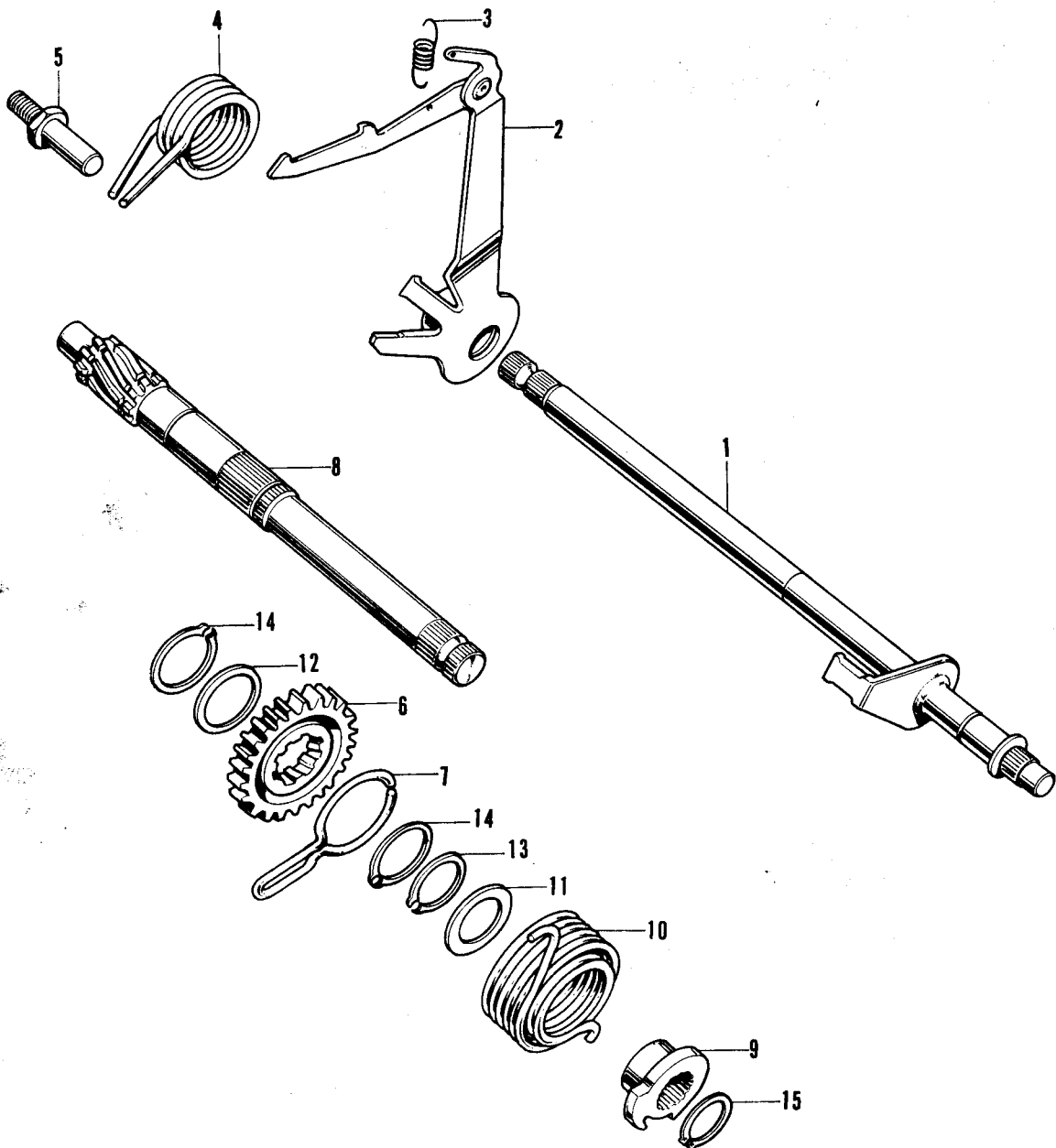

E-9 Gear Change**HONDA**

Ref. No.	Part No.	Description	Reqd. No. Z50A	No. Used on		News No.
				From	To	
1	24610-040-020	SPINDLE, gear shift	1	Z50A-100001		
2	24630-040-040	ARM, gear shift	1	Z50A-100001		
3	24641-041-000	SPRING, gear shift arm	1	Z50A-100001		
4	24651-041-000	SPRING, gear shift return	1	Z50A-100001		
5	24652-035-000	PIN, shift return spring	1	Z50A-100001		
6	28211-040-035	PINION, kick starter (22T)	1	Z50A-100001		
7	28223-035-035	SPRING, kick starter ratchet	1	Z50A-100001		
8	28251-035-065	SPINDLE, kick starter	1	Z50A-100001		
9	28262-035-020	RETAINER, kick spring	1	Z50A-100001		
10	28281-035-010	SPRING, kick starter	1	Z50A-100001		
11	90451-040-000	WASHER, thrust, 17 mm	1	Z50A-100001		
● 12	90482-035-025	WASHER, 20 mm	1	Z50A-100001		8004
13	90601-001-000	CIR-CLIP, 17 mm	1	Z50A-100001		
14	90605-200-000	SET-RING, 20 mm	2	Z50A-100001		
15	94510-16100	CIR-CLIP, 16 mm	1			

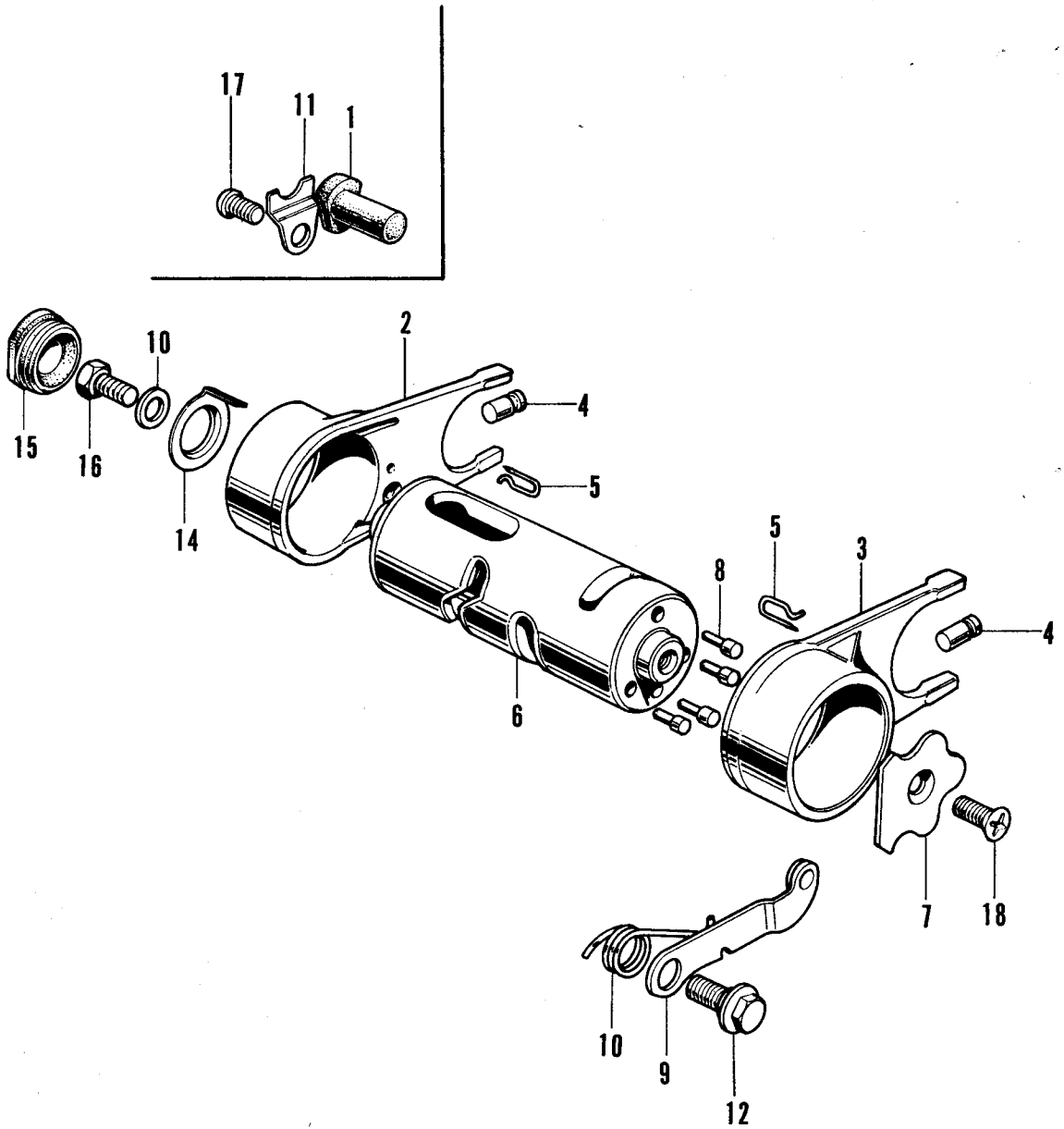

Ref. No.	Part No.	Description	Reqd. No. Z50A	No. Used on		News No.
				From	To	
1	11926-020-000	PLUG, sealing, 10 mm	1	Z50A-100001	Z50A-103922	9002
2	24211-041-000	FORK, gear shift, left	1	Z50A-100001		
3	24221-041-000	FORK, gear shift, right	1	Z50A-100001		
● 4	24261-028-010	PIN, shift fork guide	2	Z50A-100001		8006
5	24263-028-000	CLIP, gear shift guide pin	2	Z50A-100001		
6	24301-045-670	DRUM, gear shift	1	Z50A-100001		
7	24411-041-020	PLATE, shift drum stopper	1	Z50A-100001		
8	24421-041-000	PIN, shift drum	4	Z50A-100001		
9	24430-041-000	STOPPER, shift drum	1	Z50A-100001		
10	24435-040-000	SPRING, shift drum stopper	1	Z50A-100001		
11	35755-001-020	PLATE, contact fixing	1	Z50A-100001	Z50A-103922	9002
12	90023-041-000	PIVOT, shift drum stopper arm	1	Z50A-100001		
13	90417-041-000	WASHER, side, shift drum.....	1	Z50A-100001		
14	90484-045-010	WASHER, 13.2 mm	1	Z50A-100001		
15	90801-035-000	PLUG, rubber, 19 mm	1	Z50A-100001		
16	92000-06016	BOLT, hex., 6×16	1			
17	93500-06012	SCREW, pan, 6×12	1			9002
18	93600-06016	SCREW, flat, 6×16	1			

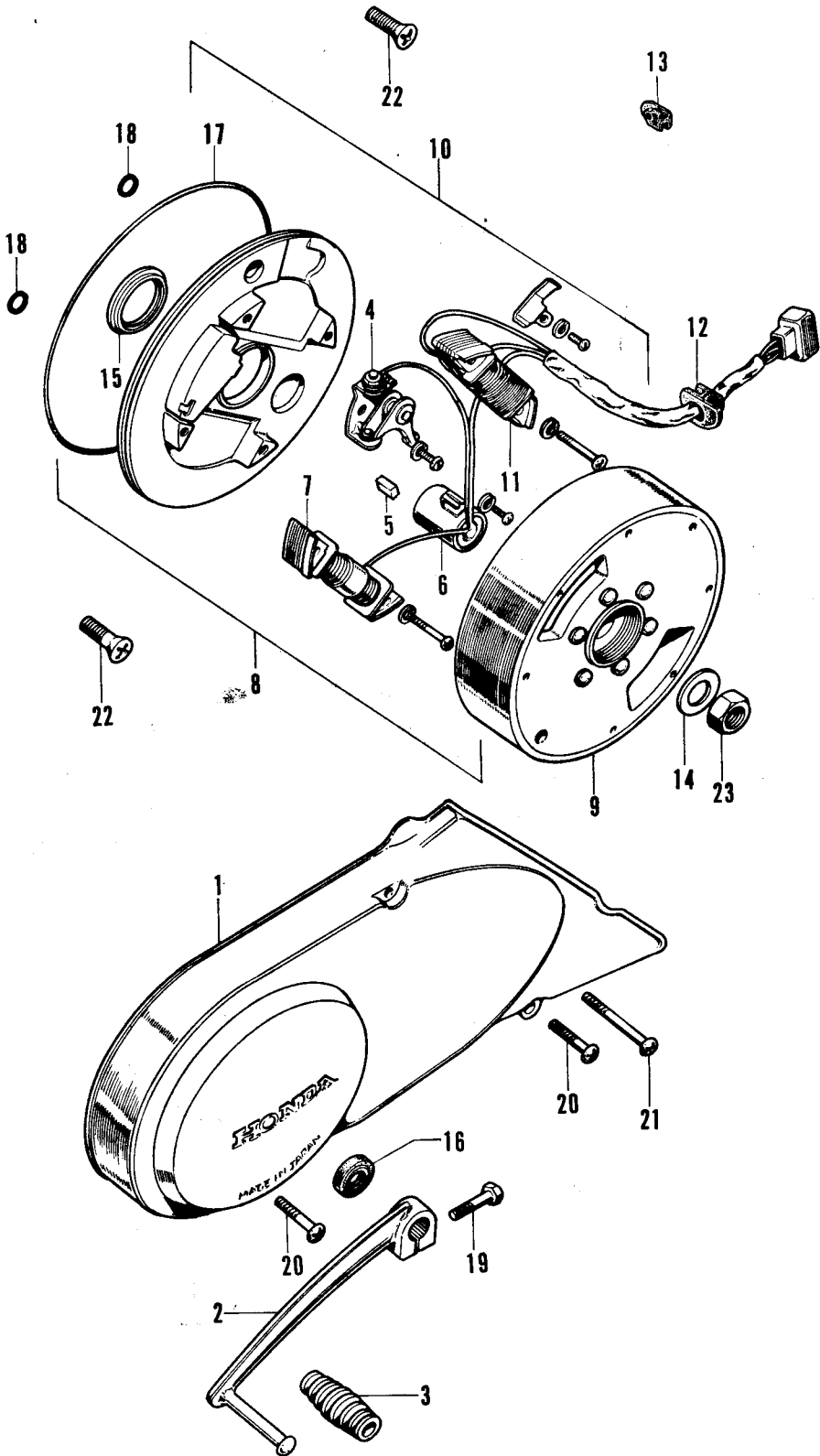

E-11 Left Crankcase Cover · Dynamo

HONDA

Ref. No.	Part No.	Description	Reqd. No. Z50A	No. Used on		News No.
				From	To	
1	11341-045-020	COVER, left crankcase	1	Z50A-100001		
2	24700-045-670	PEDAL, gear change.....	1	Z50A-100001		
3	24781-205-000	RUBBER, gear change pedal	1	Z50A-100001		
4	30202-041-005	BREAKER, contact	1	Z50A-100001		
5	30205-041-005	FELT, oil	1	Z50A-100001		
6	30250-041-005	CONDENSER	1	Z50A-100001		
7	30540-045-670	COIL, primary.....	1	Z50A-100001	Z50A-120087	
●	30540-041-005	COIL, primary.....	1	Z50A-120088		9003
8	31100-045-670	A.C. GENERATOR ASSY., flywheel ...	1	Z50A-100001	Z50A-120087	
●	31100-045-671	A.C. GENERATOR ASSY., flywheel ...	1	Z50A-120088		9003
9	31121-045-005	FLYWHEEL.....	1	Z50A-100001		
10	31141-045-670	STATOR ASSY.....	1	Z50A-100001	Z50A-120087	
●	31141-045-671	STATOR ASSY.....	1	Z50A-120088		9003
●	31631-045-005	COIL, light	1	Z50A-120088		9003
12	32971-045-670	GROMMET, cord	1	Z50A-100001	Z50A-120087	
●	32971-035-000	GROMMET, cord	1	Z50A-120088		9003
13	32981-035-000	GROMMET, neutral switch cord	1	Z50A-100001		
14	90426-035-000	WASHER, magneto fixing	1	Z50A-100001		
15	91202-035-000	OIL-SEAL, 18.9×30×5	1	Z50A-100001		
16	91203-001-000	OIL-SEAL, S11.6-24-10	1	Z50A-100001		
17	91301-035-000	O RING, 107×2	1	Z50A-100001		
18	91317-703-000	O RING, 6×1.7	2	Z50A-100001		
19	92000-06020	BOLT, hex., 6×20	1			
20	93500-06020	SCREW, pan, 6×20	2			
21	93500-06036	SCREW, pan, 6×36	1			
22	93600-06016	SCREW, flat, 6×16	2			
23	94001-10000	NUT, hex., 10 mm	1			

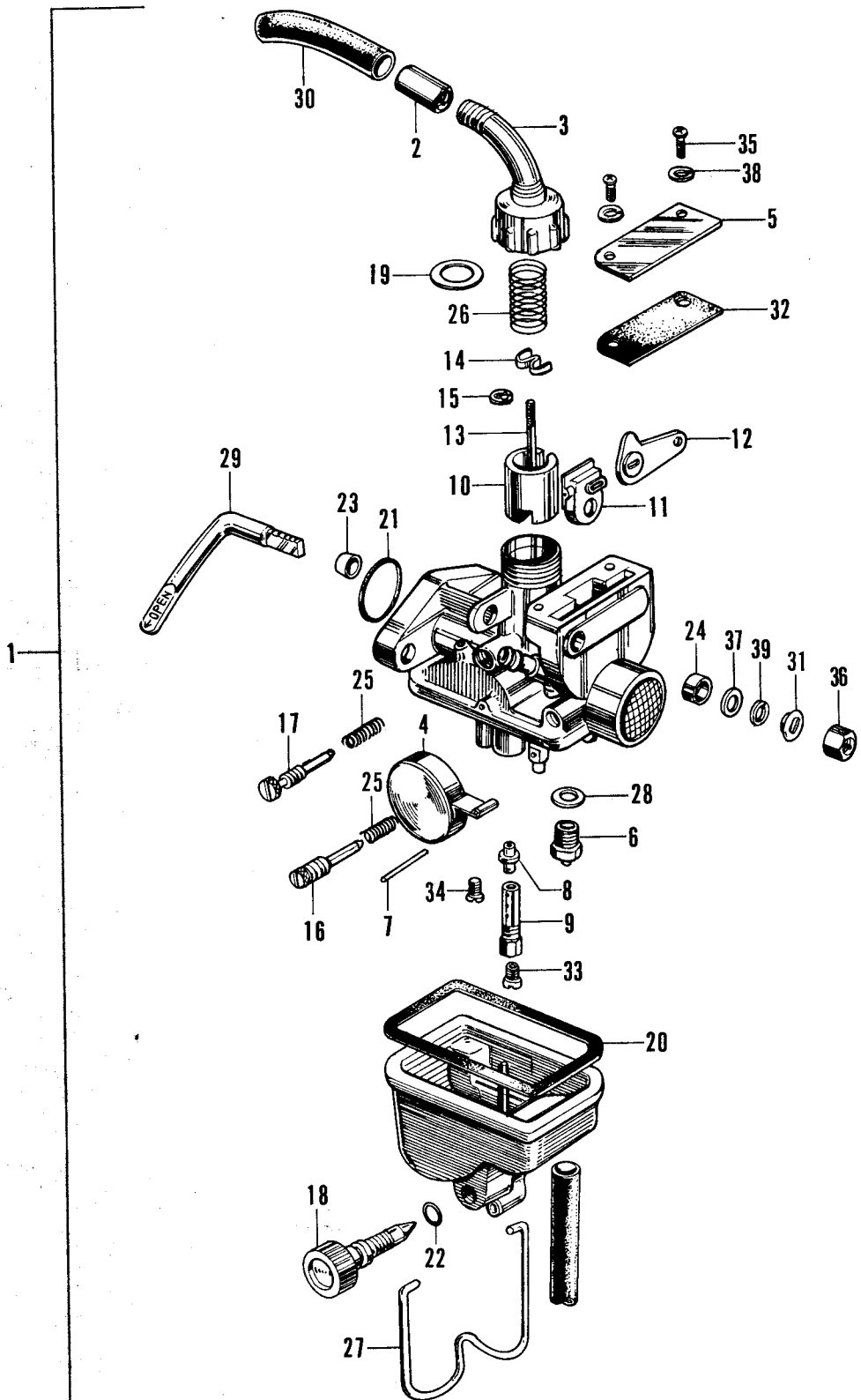

Ref. No.	Part No.	Description	Reqd. No. Z50A	No. Used on		News No.
				From	To	
1	16100-045-670	CARBURETOR ASSY.	1	Z50A-100001		
2	16118-045-004	ADJUSTER, cable	1	Z50A-100001		
3	16119-045-004	TOP	1	Z50A-100001		
4	16122-049-004	FLOAT	1	Z50A-100001		
5	16123-049-004	COVER, choke	1	Z50A-100001		
6	16125-045-004	VALVE-SET, float	1	Z50A-100001		
7	16126-011-004	PIN, float arm	1	Z50A-100001		
8	16133-045-004	JET, needle	1	Z50A-100001		
9	16139-045-004	HOLDER, needle jet	1	Z50A-100001		
10	16141-045-670	VALVE, throttle	1	Z50A-100001		
11	16142-001-004	VALVE, choke	1	Z50A-100001		
12	16143-050-004	LINK, choke	1	Z50A-100001		
13	16151-045-670	NEEDLE, jet	1	Z50A-100001		
14	16156-001-004	PLATE, needle clip	1	Z50A-100001		
15	16157-259-004	CLIP, bar	1	Z50A-010001		
16	16162-049-004	SCREW, air	1	Z50A-100001		
17	16163-049-004	SCREW, throttle stop	1	Z50A-100001		
18	16164-045-004	SCREW, drain	1	Z50A-100001		
19	16171-049-004	WASHER, top	1	Z50A-100001		
20	16172-049-004	WASHER, float chamber	1	Z50A-100001		
21	16173-023-004	O RING, 150R	1	Z50A-100001		
22	16174-045-004	O RING, 3.8R	1	Z50A-100001		
23	16178-049-004	SEAL	1	Z50A-100001		
24	16179-049-004	SEAT, sealing	1	Z50A-100001		
25	16181-001-004	SPRING, air screw	2	Z50A-100001		

E-12 Carburetor**HONDA**

Ref. No.	Part No.	Description	Reqd. No. Z50A	Used No. on		News No.
				From	To	
26	16185-045-004	SPRING, throttle.....	1	Z50A-100001		
27	16187-045-004	CLIP, float chamber set	1	Z50A-100001		
28	16188-049-004	WASHER, fiber	1	Z50A-100001		
29	16192-045-004	LEVER, choke.....	1	Z50A-100001		
30	16194-045-004	CAP, rubber	1	Z50A-100001		
31	16197-049-004	WASHER, stopper	1	Z50A-100001		
32	16198-045-004	PACKING, choke cover	1	Z50A-100001		
33	99124-05004	JET, main (#50, S.T.D.)	1			
	99124-04504	JET, main (#45)	1			
	99124-04804	JET, main (#48)	1			
	99124-05204	JET, main (#52)	1			
	99124-05504	JET, main (#55)	1			
34	99153-03804	JET, slow (#38, S.T.D.)	1			
	99153-04004	JET, slow (#40)	1			
35.	93500-03008	SCREW, cross, 3×8	2			
36	94001-05000	NUT, hex., 5 mm	1			
37	94101-05000	WASHER, plain, 5 mm.....	1			
38	94111-03000	WASHER, spring, 3 mm	2			
39	94111-05000	WASHER, spring, 5 mm	1			

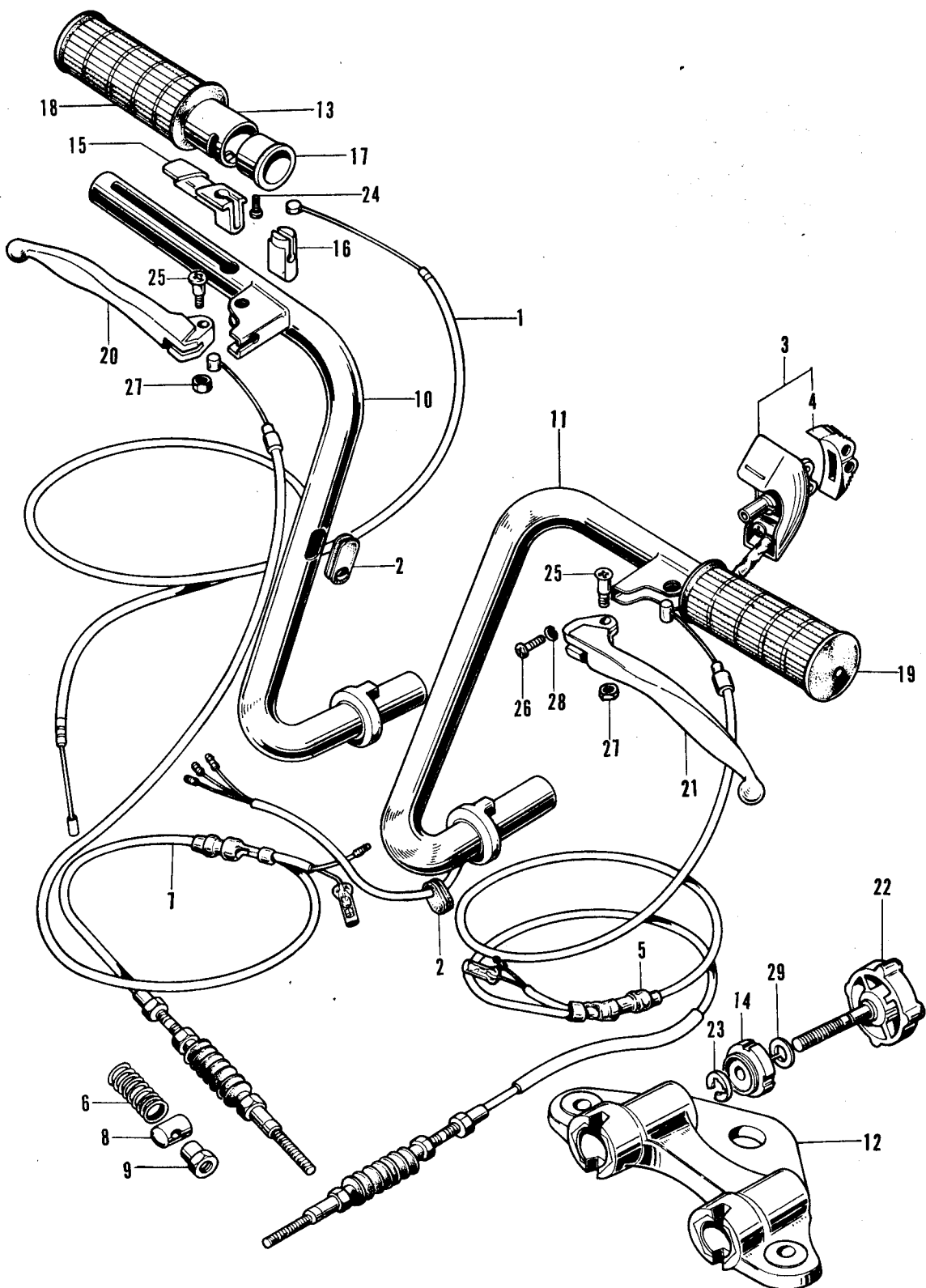

HONDA**F-1 Steering Handle**

Ref. No.	Part No.	Description	Reqd. No. Z50A	No. Used on		News No.
				From	To	
1	17910-045-670	WIRE, throttle	1	Z50A-100001		
2	17911-023-000	GROMMET, throttle wire	1	Z50A-100001	Z50A-120087	
			3	Z50A-120088		9003
● 3	35250-045-671	SWITCH ASSY., dimmer	1	Z50A-120088		9003
● 4	35316-259-300	KNOB, horn button switch	1	Z50A-120088		
5	43450-045-670	WIRE, rear brake	1	Z50A-100001	Z50A-120087	
●	43450-045-672	WIRE, rear brake	1	Z50A-120088		9003
6	45437-001-000	SPRING, front brake arm	2	Z50A-100001		
7	45450-045-670	WIRE, front brake	1	Z50A-100001	Z50A-120087	
●	45450-045-671	WIRE, front brake	1	Z50A-120088		9003
8	45461-001-000	JOINT, front brake arm	2	Z50A-100001		
9	45462-028-000	NUT, front brake arm adjusting	2	Z50A-100001		
10	53110-045-670	PIPE, right steering handle	1	Z50A-100001	Z50A-101125	
	53110-045-671	PIPE, right steering handle	1	Z50A-101126		
11	53120-045-670	PIPE, left steering handle	1	Z50A-100001	Z50A-101125	
	53120-045-671	PIPE, left steering handle	1	Z50A-101126	Z50A-120087	
●	53120-045-672	PIPE, left steering handle	1	Z50A-120088		9003
12	53131-045-670	HOLDER, steering handle	1	Z50A-100001		
13	53141-044-000	PIPE, throttle grip	1	Z50A-100001		
14	53143-045-000	NUT, handle holder	2	Z50A-100001		
15	53161-044-000	HINGE, throttle wire	1	Z50A-100001		

F-1 Steering Handle

HONDA

Ref. No.	Part No.	Description	Reqd. No. Z50A	No. Used on		News No.
				From	To	
16	53162-045-670	HOLDER, throttle cable outer	1	Z50A-100001		
17	53163-044-000	STOPPER, throttle gripe pipe	1	Z50A-100001		
18	53165-063-000XL	RUBBER, right grip	1	Z50A-100001	Z50A-120087	
●	53165-044-010	RUBBER, right grip	1	Z50A-120088		9003
19	53166-063-000XL	RUBBER, left grip	1	Z50A-100001	Z50A-120087	
●	53166-044-010	RUBBER, left grip	1	Z50A-120088		9003
20	53175-063-000XL	LEVER, right handle.....	1	Z50A-100001	Z50A-120087	
●	53175-044-010	LEVER, right handle.....	1	Z50A-120088		9003
21	53178-063-000XL	LEVER, left handle	1	Z50A-100001	Z50A-120087	
●	53178-044-010	LEVER, left handle	1	Z50A-120088		9003
22	53741-045-020	KNOB, handle holder	2	Z50A-100001	Z50A-105766	
●	53741-045-304	KNOB, handle holder	2	Z50A-105767		
23	53746-045-010	RING, knob stopper	2	Z50A-100001		
24	90101-063-000	SCREW, throttle grip setting	1	Z50A-100001		
25	90114-063-000	SCREW, handle lever pivot.....	2	Z50A-100001		
●	26	93500-03012-0A	SCREW, pan, 3 mm	1		9003
27	94001-05000-0S	NUT, hex., 5 mm	2			
●	28	94111-03000	WASHER, spring, 3 mm	1		9003
●	29	94111-08000	WASHER, spring, 8 mm	2		

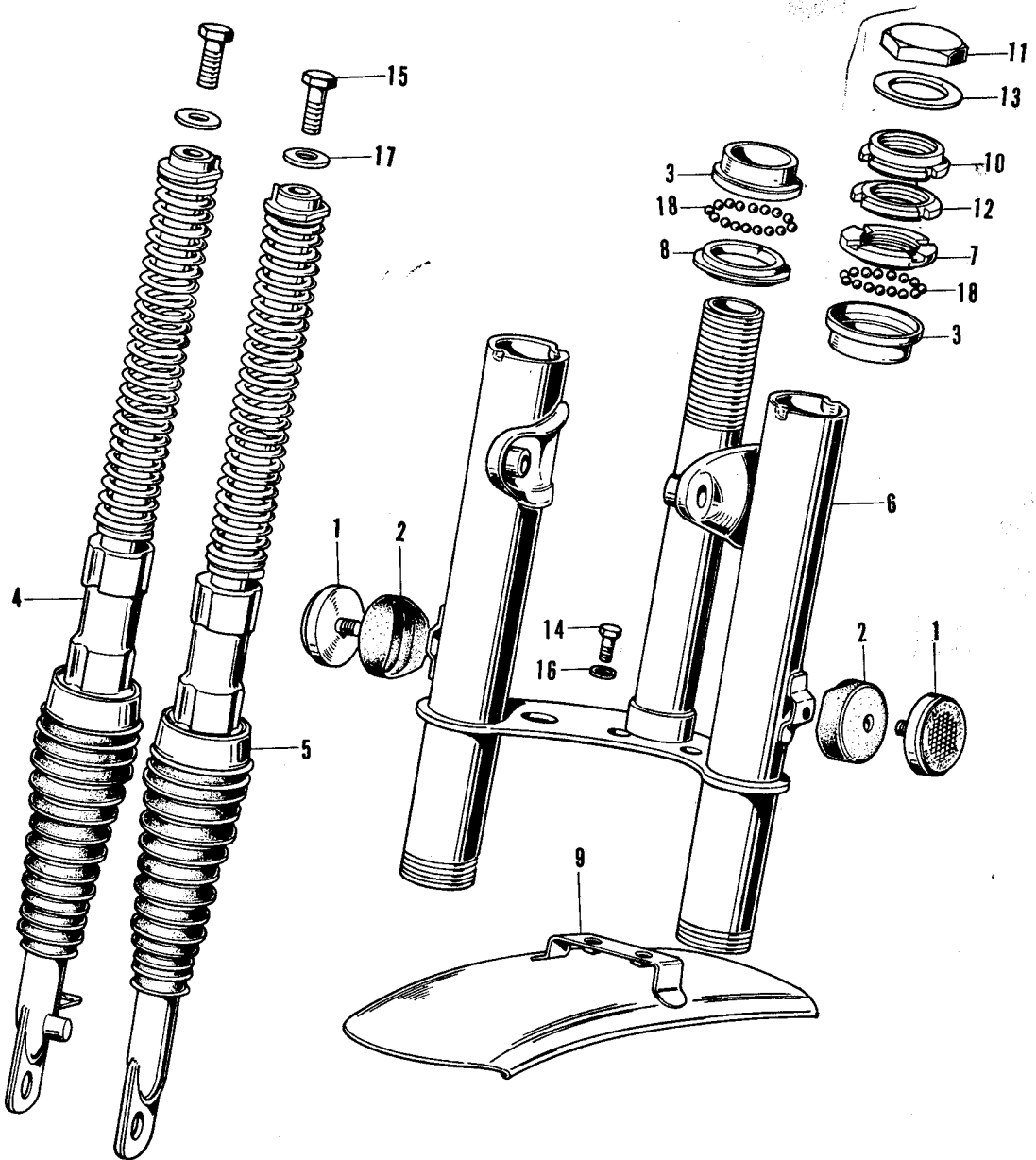

Ref. No.	Part No.	Description	Reqd. No. Z50A	No. Used on		News No.
				From	To	
● 1	33741-045-671	REFLEX REFLECTOR, front	2	Z50A-120088		9003
● 2	33744-045-670	BASE, front reflector	2	Z50A-120088		9003
3	50301-044-020	RACE, ball, steering top	2	Z50A-100001		
4	51400-045-670	CUSHION ASSY., right front	1	Z50A-100001		
5	51500-045-670	CUSHION ASSY., left front	1	Z50A-100001		
6	51510-045-670C	FORK, front (Scarlet)	1	Z50A-100001	Z50A-120087	
	51510-045-670XB	FORK, front (Bright yellow)	1	Z50A-100001	Z50A-120087	
●	51510-045-670Z	FORK, front (Base coating).....	1	Z50A-100001	Z50A-120087	8004
●	51510-045-671AA	FORK, front (Candy red).....	1	Z50A-120088		9003
●	51510-045-671AB	FORK, front (Candy blue)	1	Z50A-120088		9003
●	51510-045-671XB	FORK, front (Bright yellow)	1	Z50A-120088		9003
●	51510-045-671Z	FORK, front (Base coating).....	1	Z50A-120088		9003
7	53211-045-010	RACE, steering top cone	1	Z50A-100001		
8	53212-045-020	RACE, steering bottom cone	1	Z50A-100001		
9	61100-045-670AU	FENDER, front (Cloud silver)	1	Z50A-100001	Z50A-120087	
●	61100-045-670XW	FENDER, front (Chrome)	1	Z50A-120088		9003
10	90303-045-000	NUT A, steering stem	1	Z50A-100001		
11	90304-011-000	NUT, steering stem	1	Z50A-100001		
12	90304-045-010	NUT B, steering stem	1	Z50A-100001		
13	90503-011-000	WASHER, steering stem nut	1	Z50A-100001		
14	92000-06012	BOLT, hex., 6×12	2			
●	92000-06012	BOLT, hex., 6×12	2			9001
15	92000-10040-0A	BOLT, hex., 10×40	2			
●	93000-10040-0A	BOLT, hex., 10×40	2			9001
16	94101-06000	WASHER, plain, 6 mm.....	2			
17	94101-10000	WASHER, plain, 10 mm	2			
18	96211-06000	BALL, steel, #6	40			

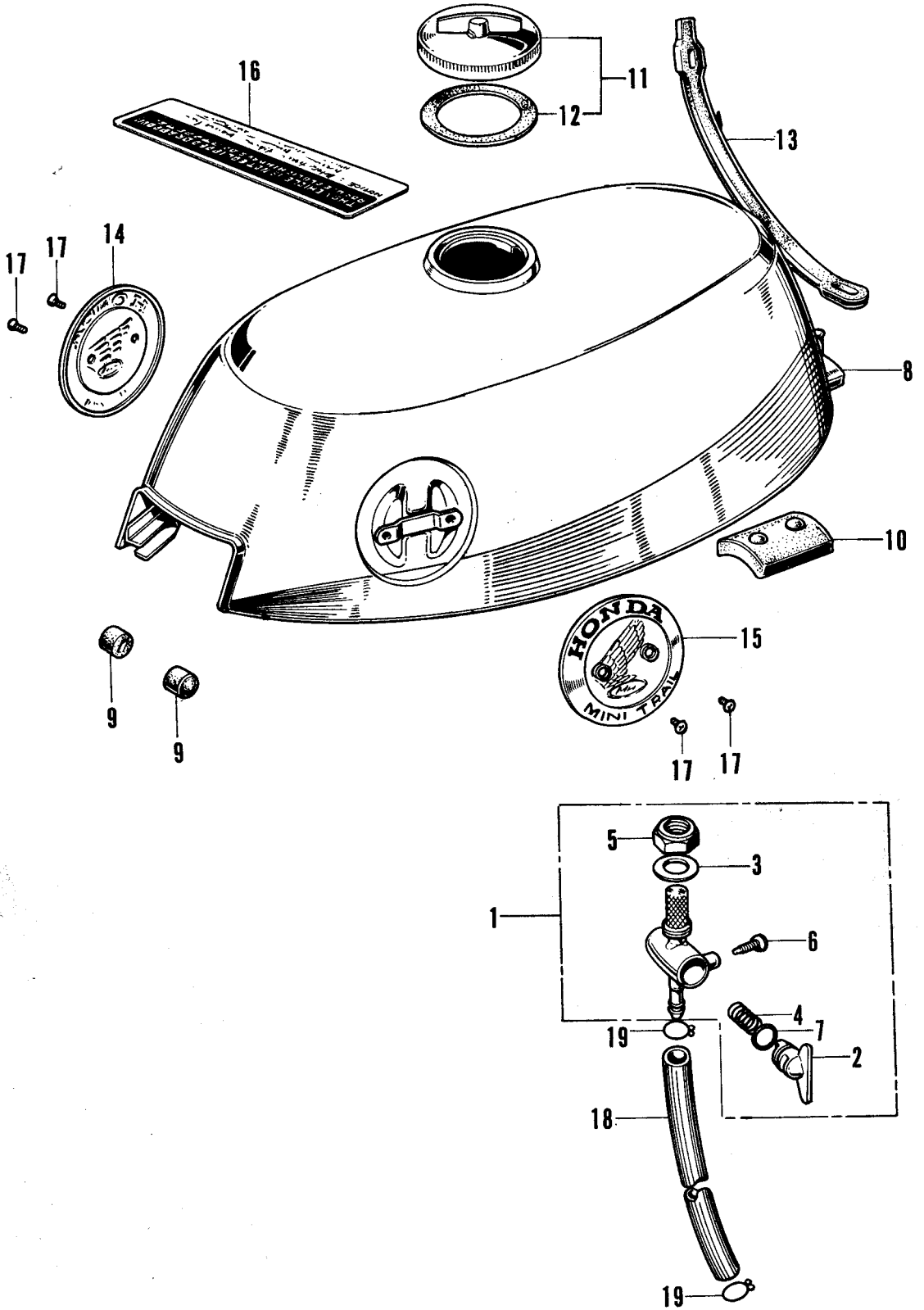

F-3 Fuel Tank

HONDA

Ref. No.	Part No.	Description	Reqd. No. Z50A	No. Used on		News No.
				From	To	
● 1	16950-044-004	COCK ASSY., fuel.....	1	Z50A-100001		8005
2	16953-044-004	LEVER, cock	1	Z50A-100001		
3	16958-044-004	PACKING, turn buckle nut	1	Z50A-100001		
4	16960-044-004	SPRING, valve	1	Z50A-100001		
5	16962-044-004	NUT, turn buckle	1	Z50A-100001		
6	16963-044-004	SCREW, lever stopper	1	Z50A-100001		
7	16997-044-004	O RING.....	1	Z50A-100001		
8	17500-045-670BV	TANK, fuel (Ivory white & scarlet).....	1	Z50A-100001	Z50A-120087	
	17500-045-670BW	TANK, fuel	1	Z50A-100001	Z50A-120087	
		(Ivory white & bright yellow)				
●	17500-045-670BR	TANK, fuel (Candy red & Cloud silver).....	1	Z50A-120088		9003
●	17500-045-670BZ	TANK, fuel (Candy blue & Cloud silver).....	1	Z50A-120088		9003
●	17500-045-670CJ	TANK, fuel (Bright yellow & Cloud silver).....	1	Z50A-120088		9003
●	17500-045-030Z	TANK, fuel (Base coating)	1	Z50A-100001		8004
9	17611-045-020	CUSHION, front, fuel tank	2	Z50A-100001		
10	17613-045-000	CUSHION, fuel tank rear	1	Z50A-100001		
11	17620-045-010	CAP, fuel filler	1	Z50A1100001		
12	17631-045-000	PACKING, fuel filler cap.....	1	Z50A-100001		
13	17670-045-670	BAND, fuel tank setting	1	Z50A-100001		
14	87121-045-670	EMBLEM, right, fuel tank	1	Z50A-100001		
15	87122-045-670	EMBLEM, left, fuel tank	1	Z50A-100001		
16	87504-045-670	PLATE A, caution.....	1	Z50A-100001	Z50A-120087	
●	87504-045-671	PLATE A, caution.....	1	Z50A-120088		9003
17	93700-03008-0B	SCREW, oval, 3×8	4			
18	95001-45100	TUBE, fuel feed, 4.5×100	1			
19	95002-45000	CLIP, fuel tube, 4.5	2			

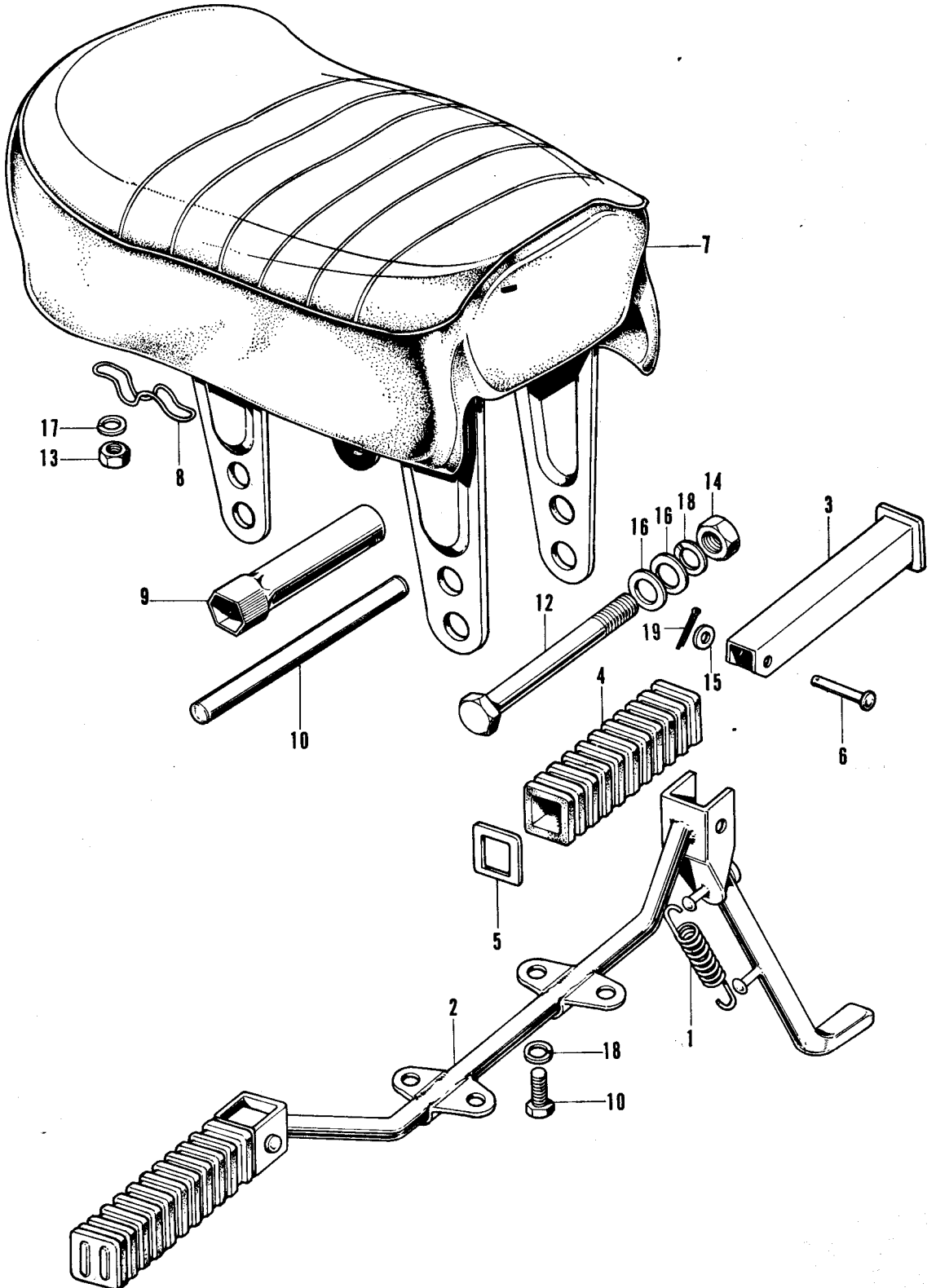

Ref. No.	Part No.	Description	Reqd. No. Z50A	No. Used on		News No.
				From	To	
1	50542-045-010	SPRING, side stand	1	Z50A-100001		
2	50610-045-670	BAR, step	1	Z50A-100001		
● 3	50701-045-670	BAR, pillion step.....	2	Z50A-100001		9003
4	50705-024-000	RUBBER, pillion step	2	Z50A-100001		
5	50712-024-000	WASHER, pillion step	2	Z50A-100001		
6	50715-024-000	PIN, pillion step	2	Z50A-100001		
7	77100-045-670A	SEAT	1	Z50A-100001		
8	77135-045-671	WIRE, sparking plug wrench holder ...	2	Z50A-100001		
9	89216-045-000	WRENCH, sparking plug.....	1	Z50A-100001	Z50A-108295	
●	89216-045-670	WRENCH, sparking plug.....	1	Z50A-108296		6001
● 10	89217-045-670	BAR, handle.....	1	Z50A-108296		9001
11	92000-08020-0A	BOLT, hex., 8×20	4			
12	92020-08111	BOLT, hex., 8×111	2			
13	94001-06000-0S	NUT, hex., 6 mm	2			
14	94001-08000	NUT, hex., 8 mm	2			
●	94001-08000-0S	NUT, hex., 8 mm	2			9001
15	94101-06000	WASHER, plain, 6 mm.....	2			
16	94101-08000	WASHER, plain, 8 mm.....	4			
17	94111-06000	WASHER, spring, 6 mm	2			
18	94111-08000	WASHER, spring, 8 mm	6			
19	94201-16150	PIN, split, 1.6×15	2			

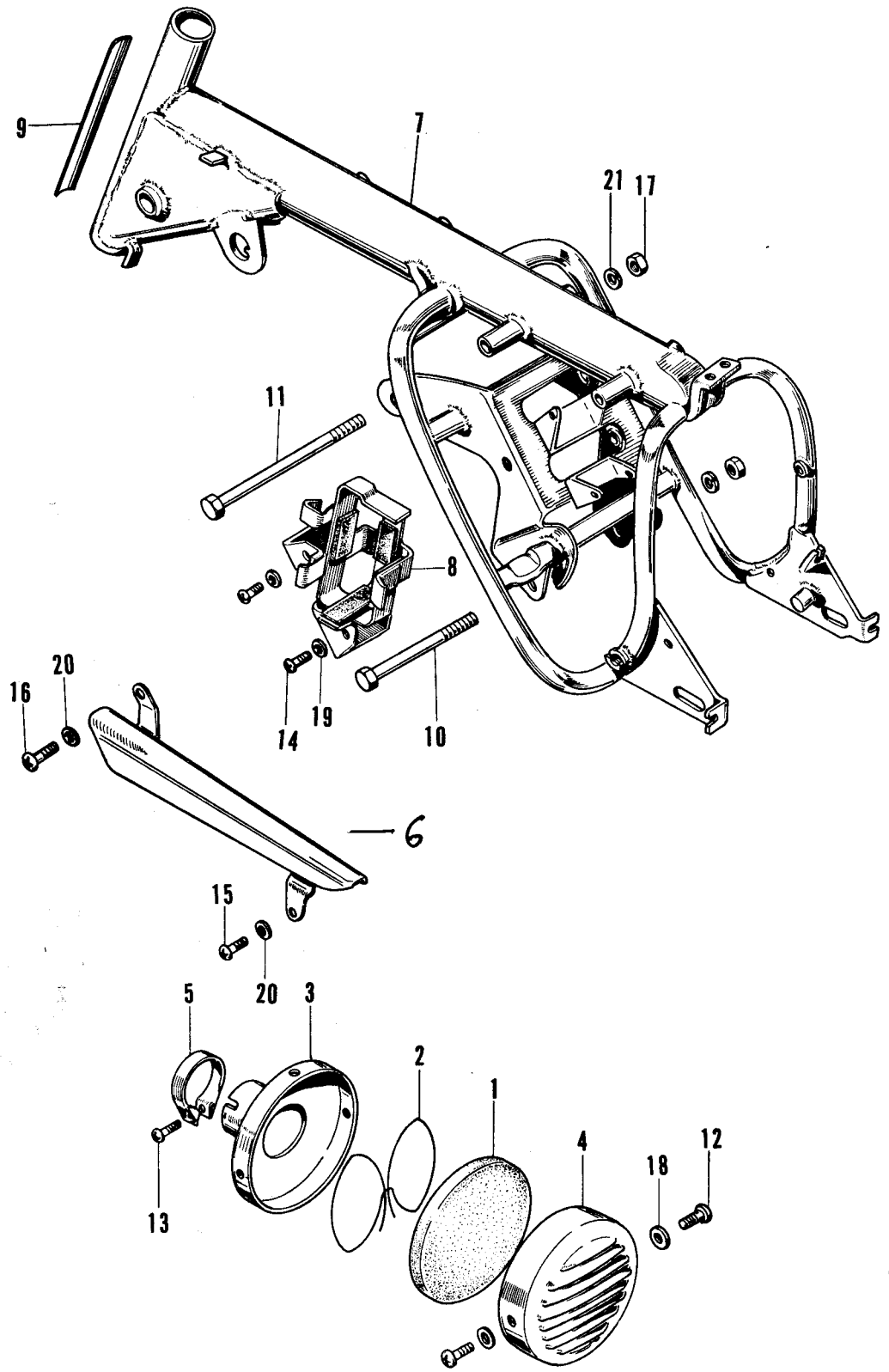

F-5 Frame Body · Air Cleaner

HONDA

Ref. No.	Part No.	Description	Reqd. No. Z50A	No. Used on		News No.
				From	To	
1	17211-045-670	ELEMENT, air cleaner.....	1	Z50A-100001		
2	17213-045-670	WIRE, element support.....	1	Z50A-100001		
3	17221-045-670	CASE, air cleaner	1	Z50A-100001		
4	17231-045-670	COVER, air cleaner	1	Z50A-100001		
5	17255-045-670	BAND, air cleaner connecting	1	Z50A-100001		
● 6	40510-045-670XW	CASE, drive chain (Chrome).....	1	Z50A-120088		9003
7	50100-045-671C	BODY, frame (Scarlet)	1	Z50A-100001	Z50A-105306	
	50100-045-671XB	BODY, frame (Bright yellow).....	1	Z50A-100001	Z50A-105306	
●	50100-045-671Z	BODY, frame (Base coating)	1	Z50A-100001	Z50A-105306	8004
●	50100-045-672C	BODY, frame (Scarlet)	1	Z50A-105307	Z50A-120087	8003
●	50100-045-672XB	BODY, frame (Bright yellow).....	1	Z50A-105307	Z50A-120087	8003
●	50100-045-672Z	BODY, frame (Base coating)	1	Z50A-105307	Z50A-120087	8008
●	50100-045-673AA	BODY, frame (Candy red)	1	Z50A-120088	Z50A-128646	9003
●	50100-045-673AB	BODY, frame (Candy blue).....	1	Z50A-120088	Z50A-128646	9003
●	50100-045-673XB	BODY, frame (Bright yellow).....	1	Z50A-120088	Z50A-128646	9003
●	50100-045-673Z	BODY, frame (Base coating)	1	Z50A-120088	Z50A-128646	9003
●	50100-045-674AA	BODY, frame (Candy red)	1	Z50M-128647		
●	50100-045-674AB	BODY, frame (Candy blue).....	1	Z50M-128647		
●	50100-045-674XB	BODY, frame (Bright yellow).....	1	Z50M-128647		
●	50100-045-674Z	BODY, frame (Base coating)	1	Z50M-128647		

Ref. No.	Part No.	Description	Reqd. No. Z50A	No. Used on		News No.
				From	To	
● 8	50380-045-670B	TRAY, battery (Black)	1	Z50A-120088	Z50A-128646	9003
●	50380-045-671B	TRAY, battery (Black)	1	Z50A-128647		
● 9	87131-045-670	LABEL, safety	1	Z50A-120088		9003
10	92000-08098	BOLT, hex., 8×98	1			
11	92000-08109	BOLT, hex., 8×109	1			
12	93500-04008-0A	SCREW, pan, 4×8	2			
13	93500-04016-0A	SCREW, pan, 4×16	1			
● 14	93500-05016-0A	SCREW, pan, 5×16	4			0039
	93500-05045-0A	SCREW, pan, 5×45	2			
● 15	93500-06008-0A	SCREW, pan, 6×8	1			9003
● 16	93500-06012-0A	SCREW, pan, 6×12	1			9003
17	94001-08000	NUT, hex., 8 mm	2			
18	94101-04000	WASHER, plain, 4 mm	2			
● 19	94101-05000	WASHER, plain, 5 mm	4			9003
20	94101-06000	WASHER, plain, 6 mm	2			
21	94111-08000	WASHER, spring, 8 mm	2			

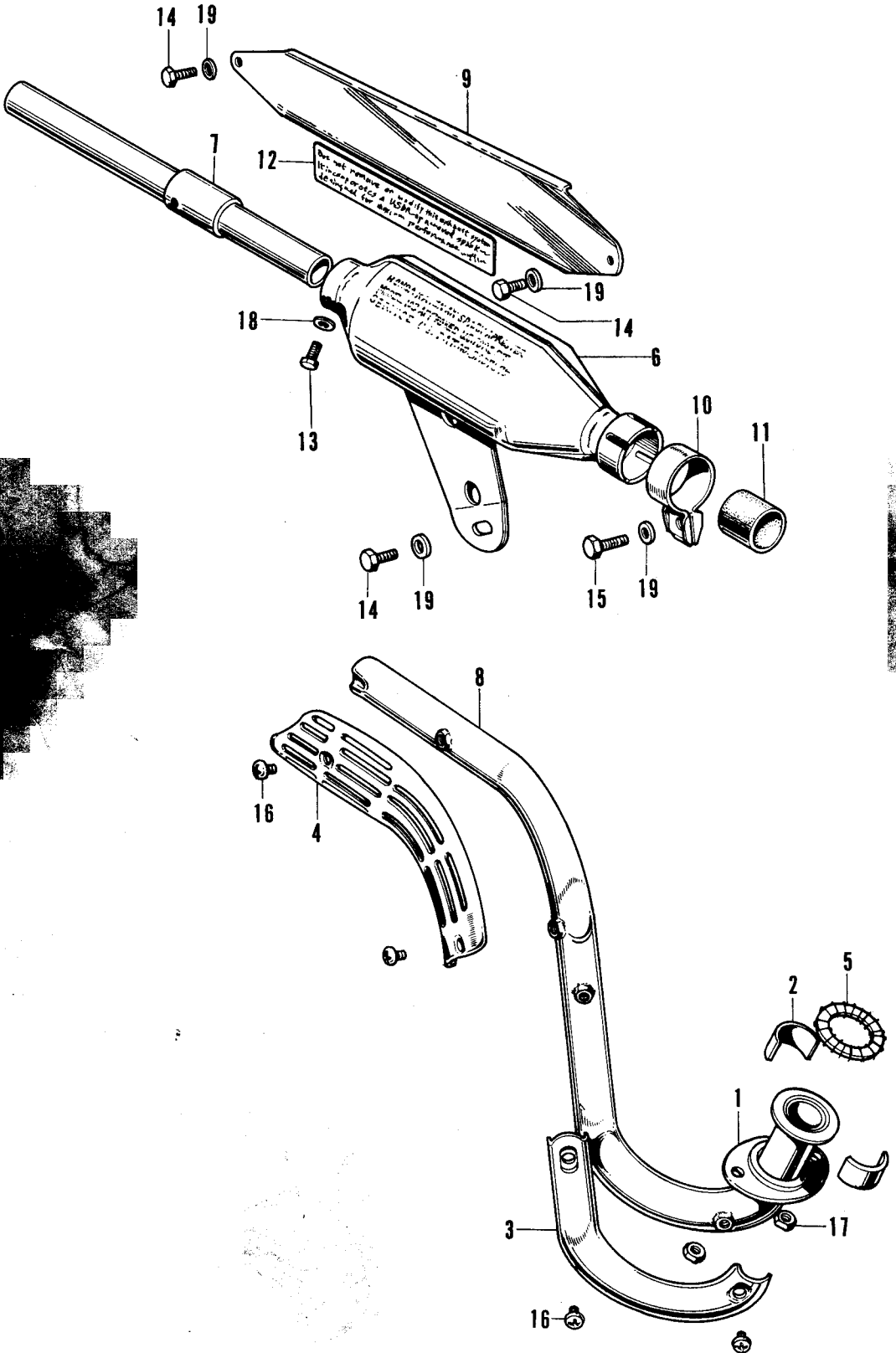

F-6 Muffler

HONDA

Ref. No.	Part No.	Description	Reqd. No. Z50A	No. Used on		News No.
				From	To	
1	18231-041-300	JOINT, exhaust pipe	1	Z50A-100001		
2	18233-040-010	COLLAR, exhaust pipe joint	2	Z50A-100001		
3	18240-045-030	COVER, exhaust pipe	1	Z50A-100001		
4	18241-045-000	PROTECTOR, exhaust pipe	1	Z50A-100001		
5	18291-001-010	GASKET, exhaust pipe.....	1	Z50A-100001		
6	18310-045-671	MUFFLER	1	Z50A-100001		
7	18311-045-671	PIPE A, diffuser	1	Z50A-100001	Z50A-120087	
●	18314-045-670	PIPE, diffuser	1	Z50A-120088		9003
8	18320-045-670	PIPE, exhaust	1	Z50A-100001		
9	18360-045-670C	PROTECTOR, muffler (Scarlet).....	1	Z50A-100001	Z50A-105306	
	18360-045-670XB	PROTECTOR, muffler (Bright yellow) ...	1	Z50A-100001	Z50A-105306	
●	18360-045-670Z	PROTECTOR, muffler (Base coating)...	1	Z50A-100001	Z50A-105306	8004
●	18360-045-671C	PROTECTOR, muffler (Scarlet).....	1	Z50A-105307	Z50A-120087	8003
●	18360-045-671XB	PROTECTOR, muffler (Bright yellow)...	1	Z50A-105307		8003
●	18360-045-671AA	PROTECTER, muffler (Candy red)	1	Z50A-120088		9003
●	18360-045-671AB	PROTECTOR, muffler (Candy blue) ...	1	Z50A-120088		9003
●	18360-045-671Z	PROTECTOR, muffler (Base coating) ...	1	Z50A-105307		8008
10	18371-045-000	BAND, exhaust pipe	1	Z50A-100001		
11	18391-045-000	PACKING, muffler.....	1	Z50A-100001		
12	87505-045-670	PLATE A, caution	1	Z50A-100001		
13	92000-05008-4J	BOLT, hex., 5×8	1	Z50A-100001		
14	92000-06012	BOLT, hex., 6×12	3			
●	92000-06012-0A	BOLT, hex., 6×12	3			9001
15	92000-06018	BOLT, hex., 6×18	1			
16	93500-05004-0A	SCREW, pan, 5×4.....	4			
17	94001-06000	NUT, hex., 6 mm	2			
●	94001-06000-0S	NUT, hex., 6 mm	2			9001
18	94101-05000	WASHER, plain, 5 mm.....	1			
19	94101-06000	WASHER, plain, 6 mm.....	4			

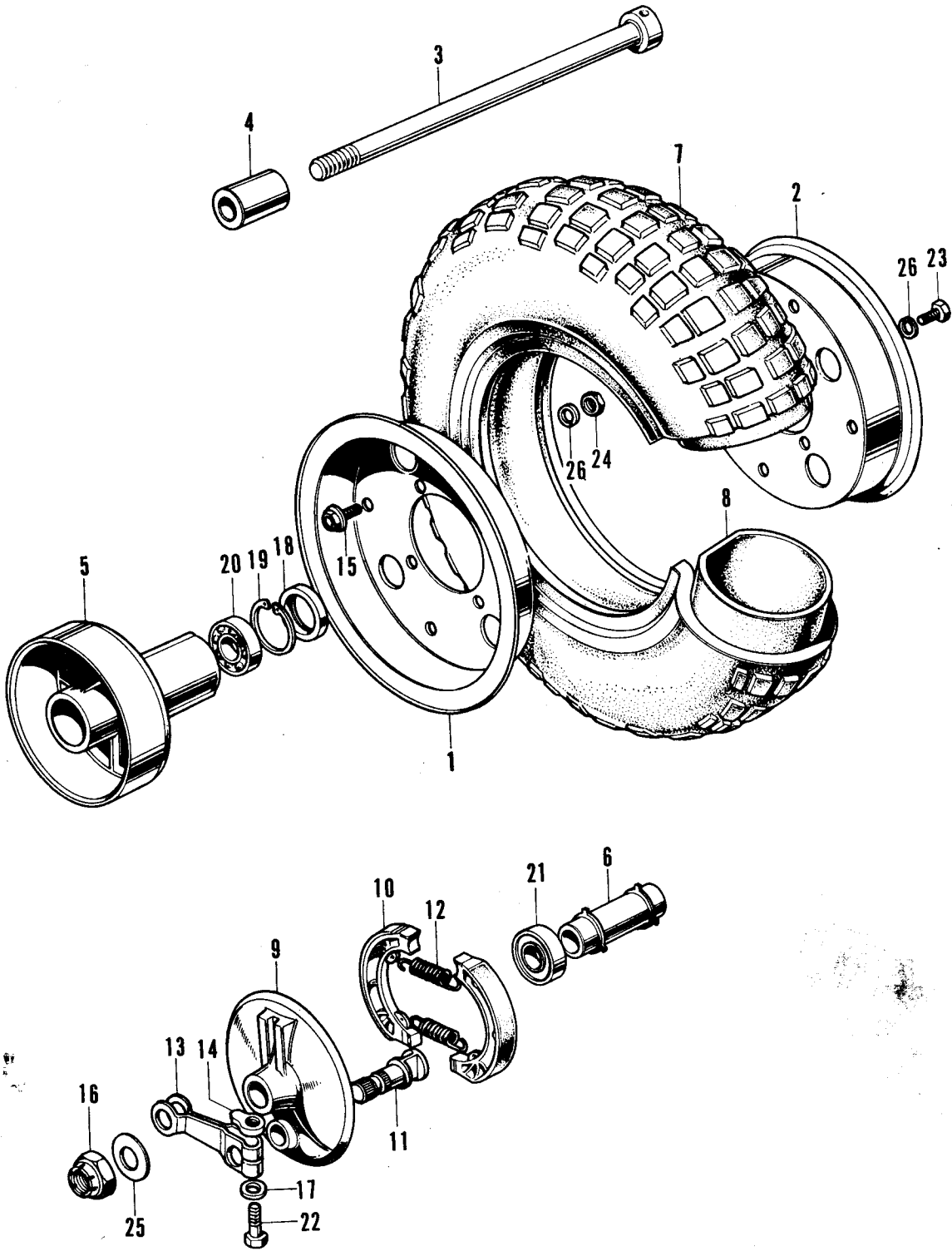

Ref. No.	Part No.	Description	Reqd. No. Z50A	No. Used on		News No.
				From	To	
1	42701-045-670AU	RIM, right wheel (Cloud silver).....	1	Z50A-100001		
2	42702-045-670AU	RIM, left wheel (Cloud silver)	1	Z50A-100001		
3	44301-045-000	AXLE, front wheel.....	1	Z50A-100001	A50Z-108295	
●	44301-045-010	AXLE, front wheel.....	1	Z50A-108296		9001
4	44311-045-670	COLLAR, front wheel	1	Z50A-100001		
5	44600-045-670	(Superseded by 44600-045-671 with 44620-045-020)	1	Z50A-100001	Z50A-100005	
	44600-045-671	HUB, front wheel	1	Z50A-100006		
6	44620-045-010	COLLAR, front axle distance.....	1	Z50A-100001	Z50A-100005	
	44620-045-020	COLLAR, front axle distance.....	1	Z50A-100006		
7	44711-045-671	TIRE, wheel (3.50-8, NITTO)	1	Z50A-100001		
	44711-045-672	TIRE, wheel (3.50-8, YOKOHAMA) ...	1	Z50A-100001		
●	44711-045-673	TIRE, wheel (3.50-8, BRIDGESTON) ...	1	Z50A-100001		9003
8	44712-045-670	TUBE, wheel	1	Z50A-100001		
9	45100-045-020	PANEL, front brake	1	Z50A-100001		
10	45120-001-010	SHOE, brake	2	Z50A-100001		
11	45131-045-000	CAM, front brake	1	Z50A-100001		
12	45133-028-000	SPRING, brake shoe.....	2	Z50A-100001		
13	45410-045-670	ARM, front brake	1	Z50A-100001		
14	45436-001-000	NUT, front brake arm setting	1	Z50A-100001		
●	90194-567-000	BOLT, sprit wheel.....	4	Z50A-100001		9003
16	90353-250-000	NUT, self lock, 12 mm	1	Z50A-100001	Z50A-108295	
●	90353-045-000	NUT, self lock, 12 mm	1	Z50A-108296		9001
17	90525-001-000	WASHER, brake arm	1	Z50A-100001		
18	91252-001-020	OIL-SEAL, 21355.5	1	Z50A-100001		
19	94520-32000	CIR-CLIP, internal, 32φ	1			
20	96100-62010	BEARING, ball, 6201.....	1			
21	96140-62010	BEARING, ball, 6201R.....	1			
22	92000-06025	BOLT, hex., 6×25	1			
23	92000-08016	BOLT, hex., 8×16	4			9003
24	94001-08000	NUT, hex., 8 mm	4			
25	94101-12000	WASHER, plain, 12 mm	1			
26	94111-08000	WASHER, spring, 8 mm	8			

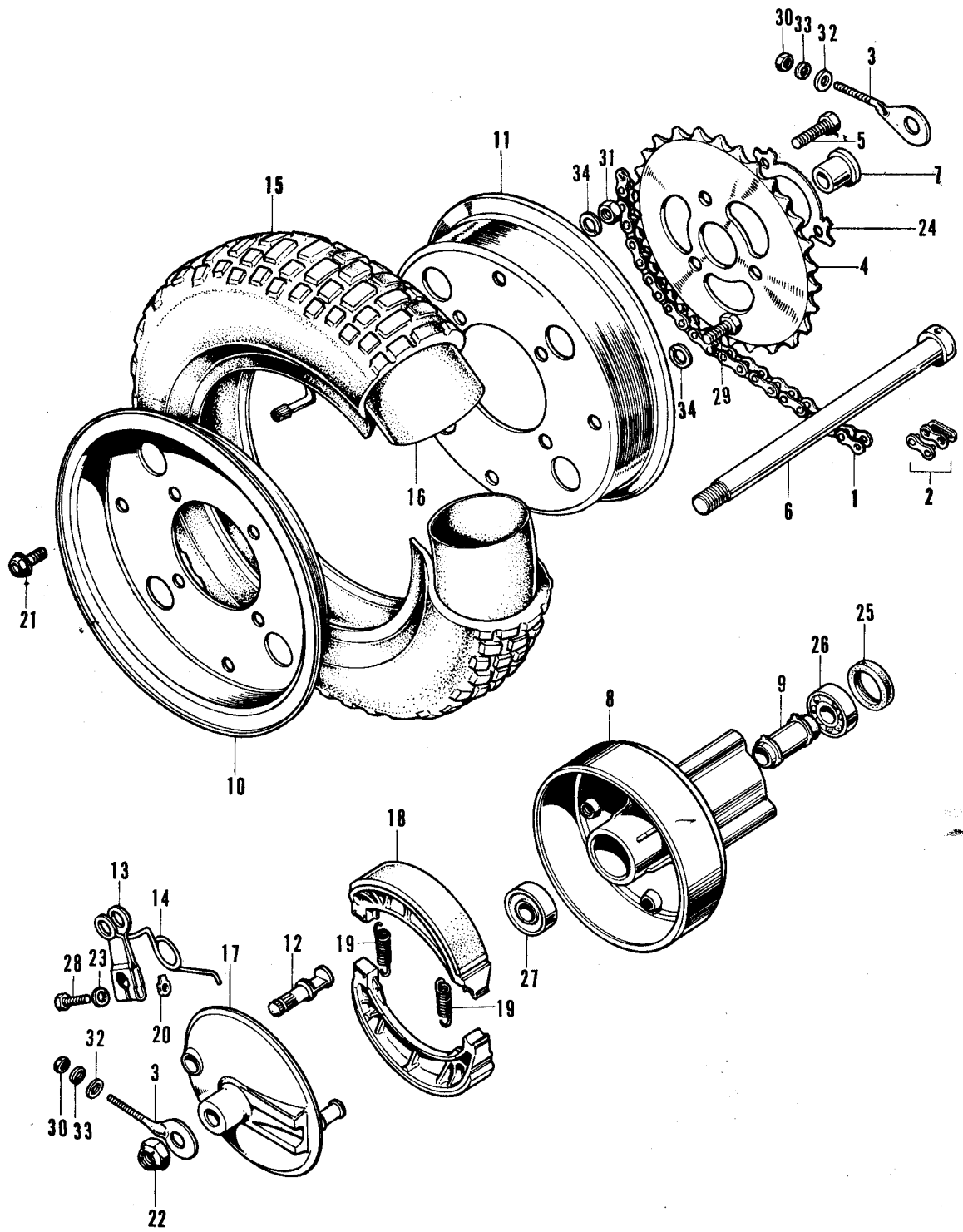

F-8 Rear Wheel

HONDA

Ref. No.	Part No.	Description	Reqd. No. Z50A	No. Used on		News No.
				From	To	
1	40530-045-670	CHAIN, drive (74L)	1	Z50A-100001	Z50A-120087	
●	40530-045-671	CHAIN, drive (74L)	1	Z50A-120088		9003
2	40531-045-010	JOINT, drive chain	1	Z50A-100001	Z50A-120087	
●	40531-045-671	JOINT, drive chain	1	Z50A-120088		9003
3	40543-032-000	ADJUSTER, drive chain	2	Z50A-100001		
4	41201-045-670	SPROCKET, final driven (34T)	1	Z50A-100001	Z50A-106900	
●	41201-045-671	SPROCKET, final driven (35T)	1	Z50A-106901	Z50A-120087	8010
●	41201-045-672	SPROCKET, final driven (35T)	1	Z50A-120088		9003
5	41209-032-000	BOLT, drive sprocket clamp	3	Z50A-100001	Z50A-106604	
	92000-08025	BOLT, hex., 8×25	3	Z50A-106605		8007
6	42301-045-000	AXLE, rear wheel	1	Z50A-100001	Z50A-108295	
●	42301-045-010	AXLE, rear wheel	1	Z50A-108296		9001
7	42311-045-000	COLLAR, rear wheel side	1	Z50A-100001		
8	42601-045-670	(Superseded by 42601-045-671 with	1	Z50A-100001		
	42620-005-020)					
	42601-045-671	HUB, rear wheel.....	1	Z50A-100001		
9	42620-045-010	COLLAR, rear axle distance	1	Z50A-100001	Z50A-100005	
	42620-045-020	COLLAR, rear axle distance	1	Z50A-100006		8009
10	42701-045-670AU	RIM, right wheel (Cloud silver).....	1	Z50A-100001		
11	42702-045-670AU	RIM, left wheel (Cloud silver)	1	Z50A-100001		
12	43141-045-000	CAM, rear brake	1	Z50A-100001		
13	43410-045-670	ARM, rear brake	1	Z50A-100001		
14	43412-045-670	SPRING, rear brake arm return.....	1	Z50A-100001		
15	44711-045-671	TIRE, wheel (3.50-8, NITTO)	1	Z50A-100001		
	44711-045-672	TIRE, wheel (3.50-8, YOKOHAMA) ...	1	Z50A-100001		
●	44711-045-673	TIRE, wheel (3.50-8, BRIDGESTONE) ...	1	Z50A-100001		9003

Ref. No.	Part No.	Description	Reqd. No. Z50A	No. Used on		News No.
				From	To	
16	44712-045-670	TUBE, wheel	1	Z50A-100001		
17	45100-045-020	PANEL, front brake	1	Z50A-100001		
18	45120-001-010	SHOE, brake	2	Z50A-100001		
19	45133-028-000	SPRING, brake shoe	2	Z50A-100001		
20	45436-001-000	NUT, front brake arm setting	1	Z50A-100001		
● 21	90194-567-000	BOLT, sprit wheel	4	Z50A-100001		9003
22	90353-250-000	NUT, self lock, 12 mm	1	Z50A-100001	Z50A-108295	
●	90353-045-000	NUT, self lock, 12 mm	1	Z50A-108296		9001
23	90525-001-000	WASHER, brake arm	1	Z50A-100001		
24	90529-045-670	WASHER, tongued, 8 mm	1	Z50A-100001		8007
25	91251-045-005	OIL-SEAL, 18328	1	Z50A-100001		
26	96100-62010	BEARING, ball, 6201	1			
27	96140-62010	BEARING, ball, 6201R	1			
28	92000-06025	BOLT, hex., 6×25	1			
29	92000-08016	BOLT, hex., 8×16	4			9003
30	94001-06000	NUT, hex., 6 mm	2			
31	94001-08000	NUT, hex., 8 mm	4			
32	94101-06000	WASHER, plain, 6 mm	2			
33	94111-06000	WASHER, spring, 6 mm	2			
34	94111-08000	WASHER, spring, 8 mm	8			

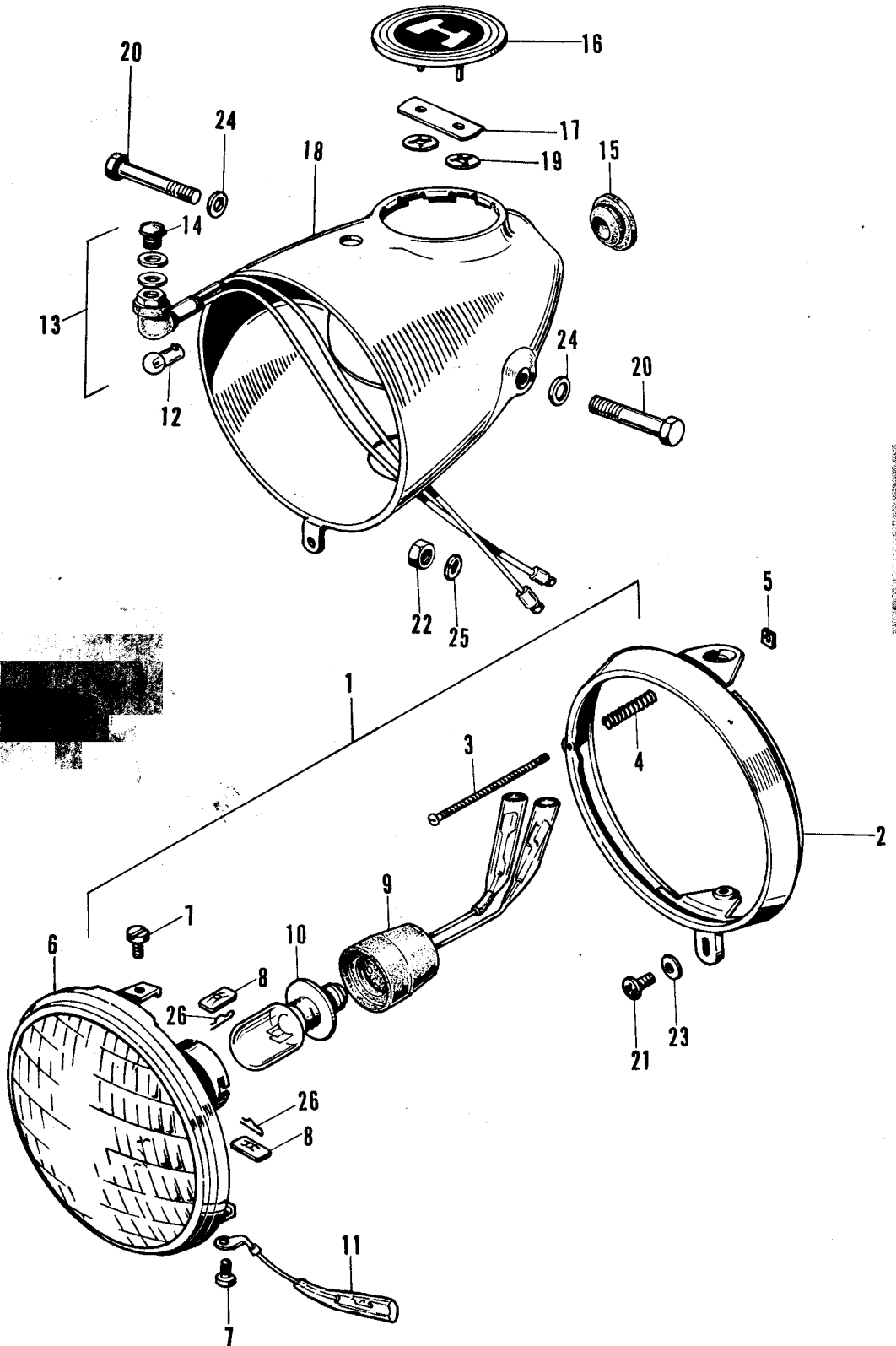

Ref. No.	Pari No.	Description	Reqd. No. Z50A	No. Used on		News No.
				From	To	
● 1	33100-063-670	LIGHT ASSY., head	1	Z50A-120088		9003
● 2	33101-063-670	RIM, head light	1	Z50A-120088		9003
● 3	33102-041-670	SCREW, beam adjusting	1	Z50A-120088		9003
● 4	33107-001-003	SPRING, beam adjusting	1	Z50A-120088		9003
● 5	33117-041-003	NUT, beam adjusting	1	Z50A-120088		9003
● 6	33120-063-670	UNIT, head light	1	Z50A-120088		9003
● 7	33125-292-670	SCREW, unit holder	2	Z50A-120088		9003
● 8	33128-292-670	NUT, unit holder	2	Z50A-120088		9003
● 9	33130-063-670	SOCKET, head light	1	Z50A-120088		9003
● 10	34901-001-671	BULB, head light (6V·15/15W)	1	Z50A-120088		9003
● 11	34902-044-670	EARTH, head light	1	Z50A-120088		9003
● 12	34908-230-000	BULB, (6V1.5W)	1	Z50A-120088		9003
● 13	37550-044-671	LAMP ASSY., beam pilot	1	Z50A-120088		9003
● 14	37551-044-670	LENS, beam pilot	1	Z50A-120088		9003
● 15	61303-045-670	PLUG, useless hole	1	Z50A-120088		9003
● 16	61402-045-670	EMBLEM, light case	1	Z50A-120088		9003
● 17	61403-045-670	PLATE, emblem setting	1	Z50A-120088		9003
● 18	63101-063-670AA	CASE, head light (Candy red)	1	Z50A-120088		9003
●	63101-063-670AB	CASE, head light (Candy blue)	1	Z50A-120088		9003
●	63101-063-670XB	CASE, head light (Bright yellow)	1	Z50A-120088		9003
●	63101-063-670Z	CASE, head light (Base coating)	1	Z50A-120088		9003
● 19	90315-504-000	NUT, spire, 3 mm	2	Z50A-120088		9003
● 20	92000-06036-0A	BOLT, hex., 6×36	2			9003
● 21	93500-05012-0A	SCREW, pan, 5×12	1			9003
● 22	94001-06000-0S	NUT, hex., 6 mm	2			9003
● 23	94101-05000	WASHER, plain, 5 mm	1			9003
● 24	94101-06000	WASHER, plain, 6 mm	2			9003
● 25	94111-06000	WASHER, spring, 6 mm	2			9003
● 26	94251-05000	PIN, lock, 5 mm	2			9003

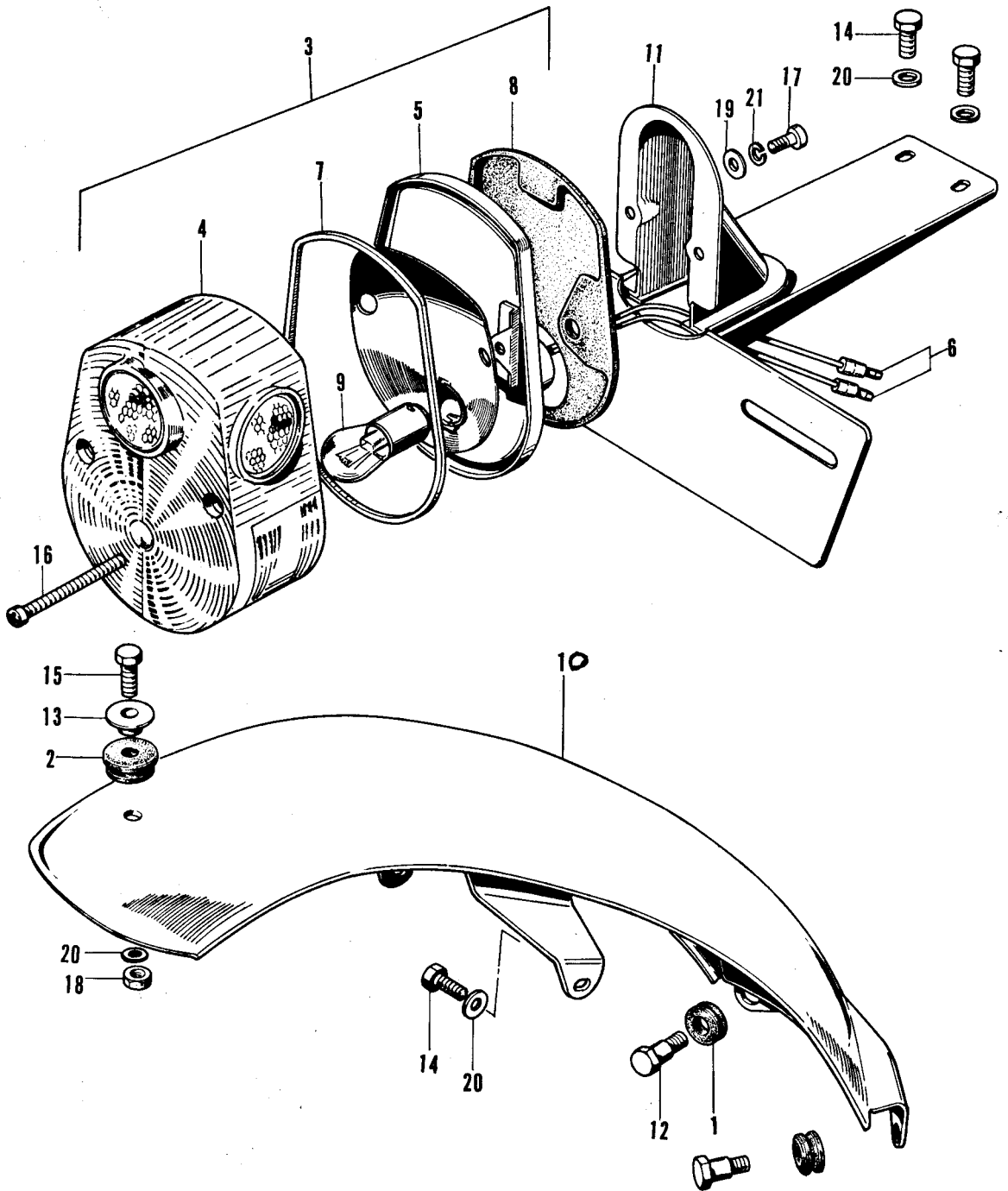

HONDA

F-10 Tail Light · Rear Fender

Ref. No.	Part No.	Description	Reqd. No. Z50A	No. Used on		News No.
				From	To	
● 1	31403-071-000	BUBBER, regulator cushion	2	Z50A-103193		8002
● 2	32983-011-000	GROMMET, wire cord.....	1	Z50A-120088		9003
● 3	33701-074-670	UNIT, tail light	1	Z50A-120088		9003
● 4	33702-074-671	LENS, tail light	1	Z50A-120088		9003
● 5	33703-074-671	BASE, tail light	1	Z50A-120088		9003
● 6	33708-077-671	CORD, tail light.....	1	Z50A-120088		9003
● 7	33709-074-671	PACKING, tail light lens.....	1	Z50A-120088		9003
● 8	33719-074-671	PACKING, tail light base	1	Z50A-120088		9003
● 9	34906-041-670	BULB, stop & tail light (6V·17/5.3W)...	1	Z50A-120088		9003
10	80100-045-670AU	(Superseded by 80100-045-671AU with 31403-071-000 (2) and 90157-001-000)	1	Z50A-100001	Z50A-103192	8002
●	80100-045-671AU	FENDER, rear (Cloud silver).....	1	Z50A-103193	Z50A-120087	8002
●	80100-045-672XW	FENDER, rear (Chrome).....	1	Z50A-120088		9003
● 11	84700-045-670B	BRACKET, number plate (Black).....	1	Z50A-120088		9003
● 12	90157-001-000	BOLT, winker relay setting.....	2	Z50A-103193		8002
● 13	90563-045-000	WASHER, number bracket mount	1	Z50A-120088		9003
14	92000-06012	BOLT, hex., 6×12	4			8002
●	92000-06012-0A	BOLT, hex., 6×12	4			9003
● 15	92000-06020-0A	BOLT, hex., 6×20	1			9003
● 16	93500-04045-0B	SCREW, pan, 4×45	2			9003
● 17	93500-05012-0A	SCREW, pan, 5×12	2			9003
● 18	94001-06000-0S	NUT, hex., 6 mm	1			9003
● 19	94101-05000	WASHER, plain, 5 mm.....	2			9003
20	94101-06000	WASHER, plain, 6 mm.....	5			9003
● 21	94111-05000	WASHER, spring	2			9003

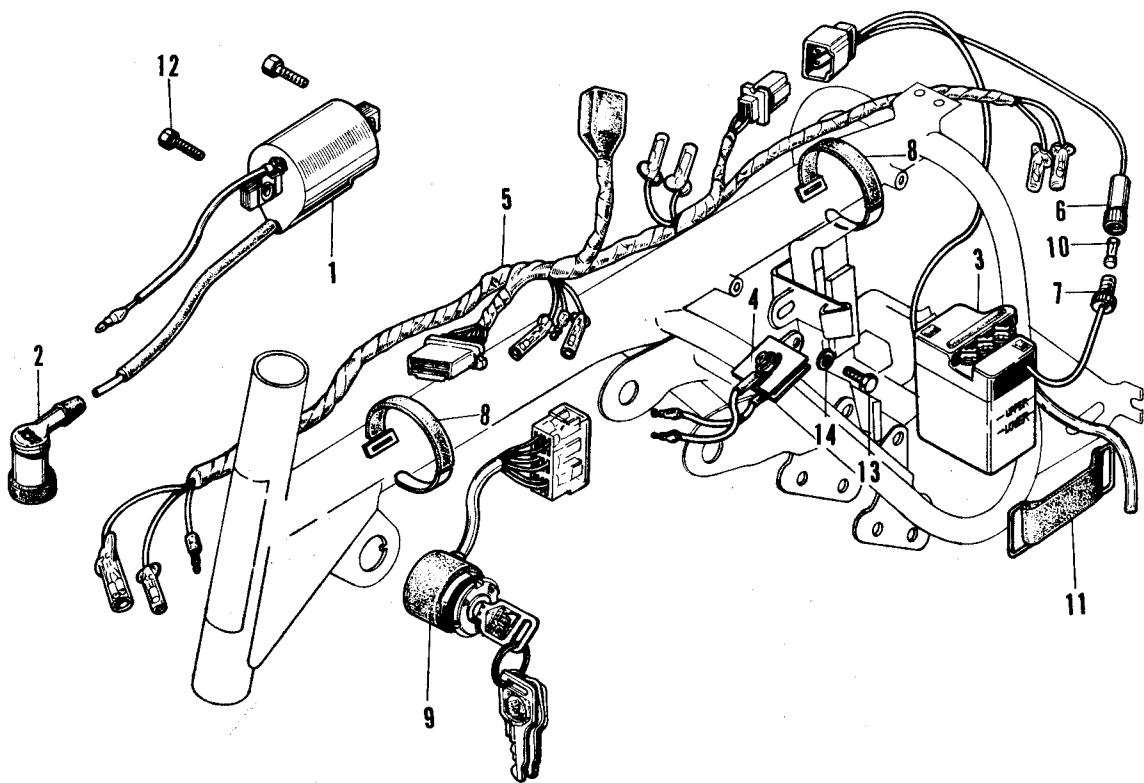

F-11 Wire Harness · Battery

HONDA

Ref. No.	Part No.	Description	Reqd. No. Z50A	No. Used on		News No.
				From	To	
1	30400-045-020	COIL, ignition	1	Z50A-100001		
● 2	30700-259-810	CAP, noise suppressor	1	Z50A-100001		
● 3	31500-045-671	BATTERY ASSY., (6V2AH)	1	Z50A-120088		9003
● 4	31700-045-671	RECTIFIRES ASSY., selenium	1	Z50A-120088		9003
● 5	32100-045-670	HARNESS, wire	1	Z50A-120088		9003
● 6	32106-041-000	CONNECTOR A, fuse	1	Z50A-120088		9003
● 7	32112-041-000	CONNECTOR B, fuse	1	Z50A-120088		9003
8	32161-001-000	BAND, wire harness	1 2	Z50A-100001 Z50A-120088	Z50A-120087	9003
9	36100-045-671	SWITCH, ASSY., starting	1	Z50A-100001	Z50A-120087	
●	35100-045-671	SWITCH ASSY., combination	1	Z50A-120088		9003
● 10	38201-001-000	FUSE, (7A)	1	Z50A-120088		9003
● 11	50382-045-670	BAND, battery	1	Z50A-120088		9003
12	92000-05020-0A	BOLT, hex., 5×20	2			
● 13	92000-06012-0A	BOLT, 6×12	1			9003
● 14	94101-06000	WASHER, plain, 6 mm	1			9003

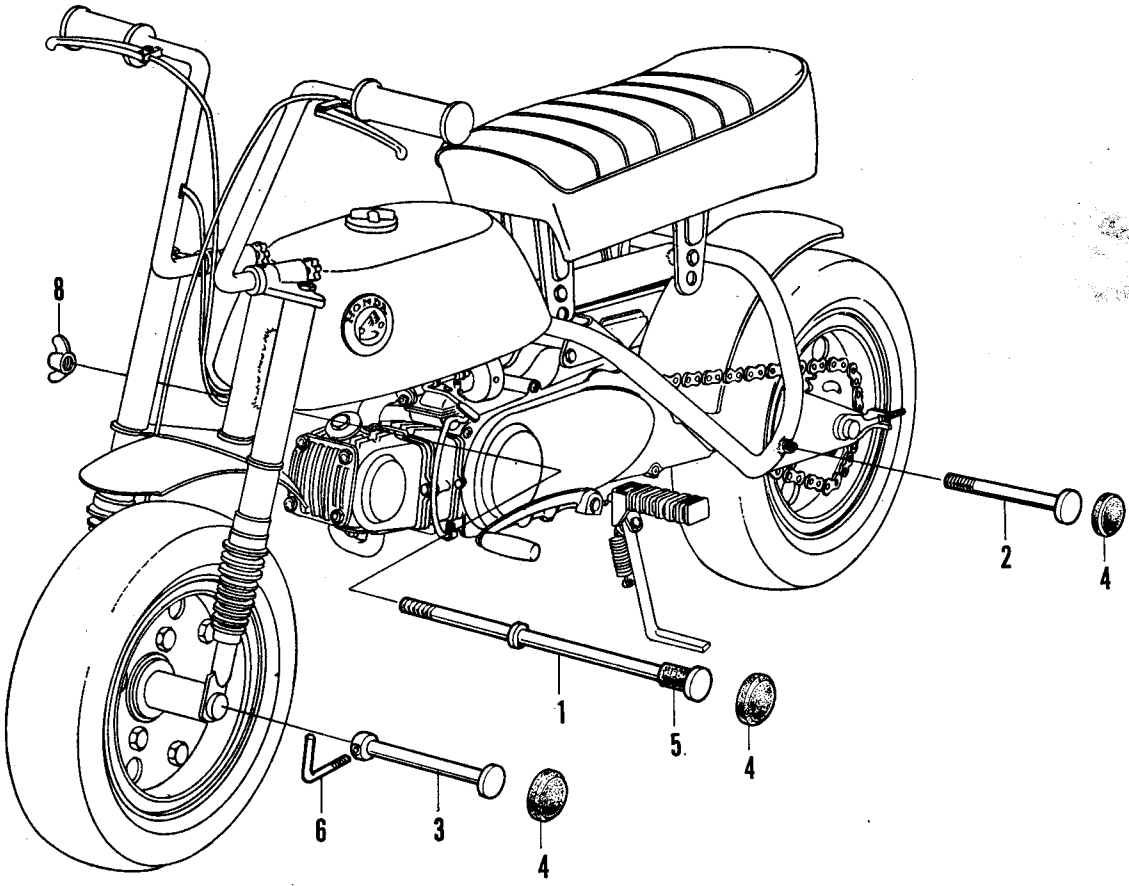
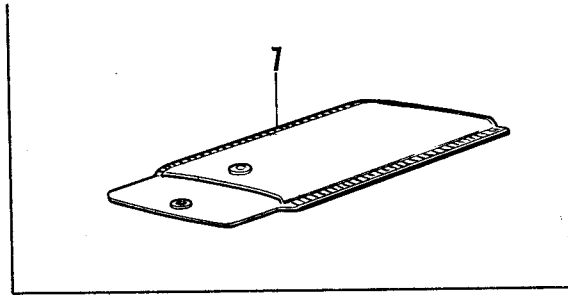

Ref. No.	Part No.	Description	Reqd. No. Z50A	No. Used on		News No.
				From	To	
	06880-045-000	ACCESSORY SET, support	1	Z50A-100001		
1	88801-045-810	STAND, frame support.....	1	Z50A-100001		
2	88802-045-810	STAND, rear support	1	Z50A-100001		
3	88803-045-810	STAND, front support	1	Z50A-100001		
4	88804-045-810	RUBBER A, support stand	3	Z50A-100001		
5	88805-045-810	RUBBER B, support stand	1	Z50A-100001		
6	88806-045-810	PIN, support stand.....	1	Z50A-100001		
7	88807-045-810	BAG, support stand	1	Z50A-100001		
8	88808-045-810	NUT, frame support	1	Z50A-100001		

Y-2 Optional Driven Sprocket

HONDA

Ref. No.	Part No.	Description	Reqd. No. Z50A	Used No. on		News No.
				From	To	
	41201-045-811	SPROCKET, final driven (38T)	1	Z50A-100001	Z50A-120087	
●	41201-045-820	SPROCKET, final driven (38T)	1	Z50A-120088		9003
	40530-045-811	CHAIN, drive (76L)	1	Z50A-100001	Z50A-120087	
●	40530-045-820	CHAIN, drive (76L)	1	Z50A-120088		9003

Ref. No.	Part No.	Description	Reqd. No. Z50A	Used No. on		News No.
				From	To	
● 1	06110-045-010	PACKING SET A	1	Z50A-100001.		
	(Content)					
	12191-035-010	GASKET, cylinder	1			
	12251-036-010	GASKET, cylinder head	1			
	12391-035-000	GASKET, cylinder head cover	1			
	12394-035-000	GASKET, cylinder head right side cover	1			
	12395-035-000	GASKET, cylinder head left side cover...	1			
	16201-045-000	GASKET, insulator	2			
	91302-001-020	O RING, 31.5 mm	2			
	91303-035-000	PACKING, rubber, 16 mm	2			
	91306-035-000	GASKET, rubber, 7.5 mm	1			
	18291-001-010	GASKET, exhaust pipe.....	1			
● 2	06111-045-010	PACKING SET B	1	Z50A-100001		
	(Content)					
	11191-035-040	GASKET, right crankcase	1			
	22119-040-000	GASKET, clutch outer cover.....	1			
	11394-035-010	GASKET, right crankcase cover	1			
	15119-035-020	GASKET, oil pump body	1			
	15329-035-000	GASKET, oil pump cover	1			
	91307-035-000	O RING, 18×3	1			
	91303-001-000	O RING, 8φ	1			
	91301-035-000	O RING, 107×2	1			
	91317-703-000	O RING, 6×1.7	2			

PART NO. INDEX

Part No.	Page	Part No.	Page	Part No.	Page	Part No.	Page
00000 Parts		13321-041-020.....	4	16000 Parts		17255-045-670.....	43
● 06110-045-010.....	64	13381-035-010.....	4	16100-045-670.....	28	● 17500-045-030Z	39
● 06111-045-010.....	64	14000 Parts		16118-045-004.....	28	17500-045-670BV ...	39
06880-045-000.....	60	14101-041-010.....	7	16119-045-004.....	28	17500-045-670BW ...	39
11000 Parts		● 14101-041-020.....	7	16122-049-004.....	28	● 17500-045-670BR	39
11100-045-000.....	11	14311-035-000.....	4	16123-049-004.....	28	● 17500-045-670BZ	39
11191-035-040.....	11	14321-035-010.....	8	16125-045-004.....	28	● 17500-045-670CJ	39
11200-045-040.....	11	14401-035-000.....	8	16126-011-004.....	28	● 17611-045-020.....	39
11330-045-010.....	16	14431-035-000.....	7	16133-045-004.....	28	17613-045-000.....	39
11341-045-020.....	27	14451-035-000.....	7	16139-045-004.....	28	17620-045-010.....	39
11394-035-000.....	16	14500-035-010.....	8	16141-045-670.....	28	17631-045-000.....	39
11926-020-000.....	24	14502-035-310.....	8	16142-001-004.....	28	17670-045-670.....	39
12000 Parts		14531-035-000.....	8	16143-050-004.....	28	17910-045-670.....	32
12021-035-811.....	7	14541-035-010.....	8	16151-045-670.....	28	17911-023-000.....	32
12023-051-310.....	7	14551-035-020.....	8	16156-001-004.....	28	18000 Parts	
12101-041-030.....	3	14566-035-000.....	8	16162-049-004.....	28	18231-041-300.....	47
12191-035-010.....	3	14591-028-000.....	8	16163-049-004.....	28	18233-040-010.....	47
12200-041-020.....	3	14610-035-010.....	8	16164-045-004.....	28	18240-045-030.....	47
12251-036-010.....	3	14615-035-000.....	8	16171-049-004.....	28	18241-045-000.....	47
12301-035-000.....	3	14670-035-030.....	8	16172-049-004.....	28	18291-001-010.....	47
12331-035-000.....	3	14675-035-060.....	8	16173-023-004.....	28	18310-045-671.....	47
12341-035-000.....	3	14711-036-000.....	7	16174-045-004.....	28	18311-045-671.....	47
12361-035-000.....	3	14721-036-000.....	7	16178-049-004.....	28	● 18314-045-670.....	47
12391-035-000.....	3	14730-028-000.....	7	16179-049-004.....	28	18320-045-670.....	47
12394-035-000.....	3	14731-028-000.....	7	16181-001-004.....	28	18360-045-670C	47
12395-035-000.....	3	14751-035-600.....	7	16185-045-004.....	31	18360-045-670XB ...	47
13000 Parts		14761-035-000.....	7	16187-045-004.....	31	● 18360-045-670Z	47
13000-041-030.....	4	14771-035-600.....	7	16188-049-004.....	31	● 18360-045-671C	47
13010-036-000.....	4	14776-028-000.....	7	16192-045-004.....	31	● 18360-045-671XB ...	47
13020-036-000.....	4	14781-001-010.....	7	16194-045-004.....	31	● 18360-045-671AA ...	47
13030-036-000.....	4	15000 Parts		16197-049-004.....	31	● 18360-045-671AB ...	47
13040-036-000.....	4	15119-035-020.....	16	16198-045-004.....	31	● 18360-045-671Z	47
13050-036-000.....	4	15300-035-000.....	16	16201-045-000.....	3	18371-045-000.....	47
13101-036-010.....	4	15311-035-000.....	16	16211-045-010.....	3	18391-045-000.....	47
13102-036-010.....	4	● 15311-035-013.....	16	16226-045-000.....	11	22000 Parts	
13103-036-010.....	4	15321-035-000.....	16	● 16950-044-004.....	39	22101-040-010.....	12
13104-036-010.....	4	15329-035-000.....	16	16953-044-004.....	39	● 22101-040-030.....	12
13105-036-010.....	4	15331-035-000.....	16	16958-044-004.....	39	22111-040-000.....	12
13111-036-000.....	4	15332-035-000.....	16	16960-044-004.....	39	22119-040-000.....	12
13115-001-000.....	4	15382-035-000.....	16	16962-044-004.....	39	22120-040-010.....	12
13201-036-000.....	4	15383-035-000.....	16	16963-044-004.....	39	22131-035-020.....	12
13211-035-000.....	4	15421-035-010.....	11	16997-044-004.....	39	22201-040-000.....	12
13310-035-050.....	4	15650-051-690.....	16	17000 Parts		22310-041-010.....	12
		15761-045-000.....	11	17111-045-040.....	3	22321-041-000.....	12
				17211-045-670.....	43	22331-041-000.....	12
				17213-045-670.....	43	22351-040-060.....	12
				17221-045-670.....	43	● 22351-040-070.....	12
				17231-045-670.....	43		

INDEX

PART NO. INDEX

Part No.	Page	Part No.	Page	Part No.	Page	Part No.	Page
22401-040-010.....12		25000 Parts		32971-045-670.....27		38000 Parts	
22411-041-000.....12		● 25551-040-007.....15		32981-035-000.....27		● 38201-001-000.....59	
22421-040-000.....12		25555-065-000.....15					
22811-040-020.....12							
22820-046-000.....12		28000 Parts		33000 Parts		40000 Parts	
22825-046-000.....12		28211-040-035.....23		● 33100-063-670.....55		● 40510-045-670XW...43	
22830-041-000.....16		28223-035-035.....23		● 33101-063-670.....55		40530-045-670.....51	
22846-040-010.....16		28251-035-065.....23		● 33102-041-670.....55		● 40530-045-671.....51	
22860-041-000.....12		28251-035-065.....23		● 33107-001-003.....55		40530-045-811.....63	
22901-001-000.....12		28262-035-020.....23		● 33117-041-003.....55		● 40530-045-820.....63	
22901-040-000.....12		28281-035-010.....23		● 33120-063-670.....55		40531-045-010.....51	
22911-035-010..... 4		28300-033-000.....16		● 33125-292-670.....55		● 40531-045-671.....51	
		28301-053-000.....16		● 33128-292-670.....55		40543-032-000.....51	
23000 Parts		28302-033-000.....16		● 33130-063-670.....55			
23110-036-000.....12		28303-001-000.....16		● 33701-074-670.....56			
23112-041-010.....15		28311-001-000.....16		● 33702-074-671.....56		41000 Parts	
23120-036-010.....15		28322-001-000.....16		● 33703-074-671.....56		41201-045-670.....51	
23211-041-020.....20		28324-001-000.....19		● 33708-077-671.....56		● 41201-045-671.....51	
23221-041-040.....20				● 33709-074-671.....56		● 41201-045-672.....51	
23421-076-000.....20		30000 Parts		● 33719-074-671.....56		41201-045-811.....63	
23431-041-040.....20		30202-041-005.....27		● 33741-045-671.....36		● 41201-045-820.....63	
23441-041-060.....20		30205-041-005.....27		● 33744-045-670.....36		41209-032-000.....51	
23471-041-040.....20		30250-041-005.....27					
23481-041-020.....20		30400-045-020.....59		34000 Parts		42000 Parts	
23800-045-000.....20		30540-045-670.....27		● 34901-001-671.....55		42301-045-000.....51	
● 23800-045-670.....20		● 30540-041-005.....27		● 34902-044-670.....55		● 42301-045-010.....51	
● 23800-045-671.....20		● 30700-259-810.....59		● 34906-041-670.....56		42311-045-000.....51	
23802-041-000.....20				● 34908-230-000.....55		42601-045-671.....51	
● 23802-065-305.....20						42620-045-010.....51	
23911-041-010.....20						42620-045-020.....51	
		31000 Parts		35000 Parts		42701-045-670AU ...48,	
24000 Parts		31100-045-670.....27		● 35100-045-671.....59		51	
24211-041-000.....24		● 31100-045-671.....27		● 35250-045-671.....32		42702-045-670AU ...48,	
24221-041-000.....24		31121-045-005.....27		● 35316-259-300.....32		51	
● 24261-028-010.....24		31141-045-670.....27		35755-001-020.....24			
24263-028-000.....24		● 31141-045-671.....27					
24301-045-670.....24		● 31403-071-000.....56					
24411-041-020.....24		● 31500-045-671.....59		36000 Parts		43000 Parts	
24421-041-000.....24		● 31631-045-005.....27		36100-045-671.....59		43141-045-000.....51	
24430-041-000.....24		● 31700-045-671.....59				43410-045-670.....51	
24435-040-000.....24						43412-045-670.....51	
24610-040-020.....23		32000 Parts		37000 Parts		43450-045-670.....32	
24630-040-040.....23		● 32100-045-670.....59		● 37550-044-671.....55		● 43450-045-672.....32	
24641-041-000.....23		● 32106-041-000.....59		● 37551-044-670.....55			
24651-041-000.....28		● 32112-041-000.....59					
24652-035-000.....23		32161-001-000.....59				44000 Parts	
24700-045-670.....27		● 32971-035-000.....27				44301-045-000.....48	
24781-205-000.....27							

PART NO. INDEX

Part No.	Page	Part No.	Page	Part No.	Page	Part No.	Page
<ul style="list-style-type: none"> ● 44301-045-010.....48 44311-045-670.....48 44600-045-671.....48 44620-045-010.....48 44620-045-020.....48 44711-045-671... 48,51 44711-045-672... 48,51 ● 44711-045-673.....48 ● 44712-045-670... 48,52 <p style="text-align: center;">45000 Parts</p> <ul style="list-style-type: none"> 45100-045-020... 48,52 45120-001-010... 48,52 45131-045-000.....48 45133-028-000... 48,52 45410-045-670.....48 45436-001-000... 48,52 45437-001-000.....32 45450-045-670.....32 ● 45450-045-671.....32 45461-001-000.....32 45462-028-000.....32 <p style="text-align: center;">50000 Parts</p> <ul style="list-style-type: none"> 50100-045-671C43 50100-045-671XB ...43 ● 50100-045-671Z43 ● 50100-045-672C43 ● 50100-045-672XB ...43 ● 50100-045-672Z43 ● 50100-045-673AA ...43 ● 50100-045-673AB ...43 ● 50100-045-673XB ...43 ● 50100-045-673Z43 ● 50100-045-674AA ...43 ● 50100-045-674AB ...43 ● 50100-045-674XB ...43 ● 50100-045-674Z43 50301-044-020.....36 ● 50380-045-670B44 ● 50380-045-671B44 ● 50382-045-670.....59 50542-045-010.....40 50610-045-670.....40 ● 50701-045-670.....40 50705-024-000.....40 50712-024-000.....40 50715-024-000.....40 	<p style="text-align: center;">51000 Parts</p> <ul style="list-style-type: none"> 51400-045-670.....36 51500-045-670.....36 51510-045-670C36 51510-045-670XB ...36 ● 51510-045-670Z36 ● 51510-045-671AA ...36 ● 51510-045-671AB ...36 ● 51510-045-671XB ...36 ● 51510-045-671Z36 <p style="text-align: center;">53000 Parts</p> <ul style="list-style-type: none"> 53110-045-670.....32 53110-045-671.....32 53120-045-670.....32 53120-045-671.....32 ● 53120-045-672.....32 53131-045-670.....32 53141-044-000.....32 53143-045-000.....32 53161-044-000.....32 53162-045-670.....35 53163-044-000.....35 ● 53165-044-010.....35 53165-063-000XL ...35 ● 53166-044-010.....35 53166-063-000XL ...35 ● 53175-044-010.....35 53175-063-000XL ...35 ● 53178-044-010.....35 53178-063-000XL ...35 53211-045-010.....36 53212-045-020.....36 53741-045-020.....35 ● 53741-045-304.....35 53746-045-010.....35 <p style="text-align: center;">61000 Parts</p> <ul style="list-style-type: none"> 61100-045-670AU ...36 ● 61100-045-670XW ...36 ● 61303-045-670.....55 ● 61402-045-670.....55 ● 61403-045-670.....55 <p style="text-align: center;">63000 Parts</p> <ul style="list-style-type: none"> ● 63101-063-670AA ...55 	<ul style="list-style-type: none"> ● 63101-063-670AB ...55 ● 63101-063-670XB ...55 ● 63101-063-670Z55 <p style="text-align: center;">77000 Parts</p> <ul style="list-style-type: none"> 77100-045-670A40 77135-045-671.....40 <p style="text-align: center;">80000 Parts</p> <ul style="list-style-type: none"> ● 80100-045-671AU ...56 ● 80100-045-672XW ...56 <p style="text-align: center;">84000 Parts</p> <ul style="list-style-type: none"> ● 84700-045-670B56 <p style="text-align: center;">87000 Parts</p> <ul style="list-style-type: none"> 87121-045-670.....39 87122-045-670.....39 ● 87131-045-670.....44 87504-045-670.....39 ● 87504-045-671.....39 87505-045-670.....47 <p style="text-align: center;">88000 Parts</p> <ul style="list-style-type: none"> 88801-045-810.....60 88802-045-810.....60 88803-045-810.....60 88804-045-810.....60 88805-045-810.....60 88806-045-810.....60 88807-045-810.....60 88808-045-810.....60 <p style="text-align: center;">89000 Parts</p> <ul style="list-style-type: none"> 89216-045-000.....40 ● 89216-045-670.....40 ● 89217-045-670.....40 	<p style="text-align: center;">90000 Parts</p> <ul style="list-style-type: none"> 90012-200-000..... 7 90023-041-000.....24 90031-035-010.....11 90032-035-000.....11 90033-041-000..... 3 90081-035-000..... 8 90082-035-000..... 3 90083-035-000..... 8 ● 90083-035-010..... 8 90084-041-000.....20 90101-063-000.....35 90114-063-000.....35 ● 90157-001-000.....56 ● 90194-567-000 ...48,52 90206-001-000..... 7 90231-041-000.....15 90303-045-000.....36 90304-011-000.....36 90304-045-010.....36 ● 90315-504-000.....55 ● 90353-045-000 ...48,52 90353-250-000... 48,52 90407-259-000.....11 90417-041-000.....24 90426-035-000.....27 90431-001-000.....15 90441-035-000..... 8 90442-035-000..... 3 90443-035-000..... 3 90451-001-000.....20 90451-035-000.....20 90451-040-000.....23 90461-001-000.....20 90481-035-000..... 8 ● 90482-035-025..... 23 90483-040-000.....15 90484-045-010.....24 90485-040-000.....19 90503-011-000.....36 90525-001-000... 48,52 ● 90529-045-670.....52 ● 90563-045-000.....56 90601-001-000... 15,20, 23 90605-200-000.....23 ● 90704-035-000.....11 90741-035-000..... 4 90801-035-000.....24 				

PART NO. INDEX

Part No.	Page	Part No.	Page	Part No.	Page
91000 Parts		98056-56721.....	7		
91001-035-000.....	4	99000 Parts			
91101-001-030.....	4	99124-04504.....	31		
91102-041-000.....	15	99124-04804.....	31		
91202-035-000.....	27	99124-05004.....	31		
91202-216-000.....	19	99124-05204.....	31		
91203-001-000.....	27	99124-05504.....	31		
91203-035-000.....	20	99153-03804.....	31		
91251-045-005.....	52	99153-04004.....	31		
91252-001-020.....	48				
91301-035-000.....	27				
91302-001-020.....	3				
91303-001-000.....	19				
91303-035-000.....	3				
91306-028-000.....	7				
91306-035-000.....	3				
91307-035-000.....	19				
91317-703-000.....	27				
92000 Parts					
92712-0602510.....	3				
92800-12000.....	11				
94000 Parts					
94301-08120.....	11				
94301-08140.....	3				
94510-16100.....	23				
94520-32000.....	48				
95000 Parts					
95001-45100.....	39				
95002-45000.....	39				
96000 Parts					
96100-60000.....	15				
96100-62010.....	48, 52				
96100-62030.....	20				
96140-62010.....	48, 52				
96211-06000.....	36				
98000 Parts					
98056-56711.....	7				